

SACE Emax 2

Measurement Enabler/Measurement Enabler with voltage socket - E2.2-E4.2-E6.2

E2.2-E4.2-E6.2

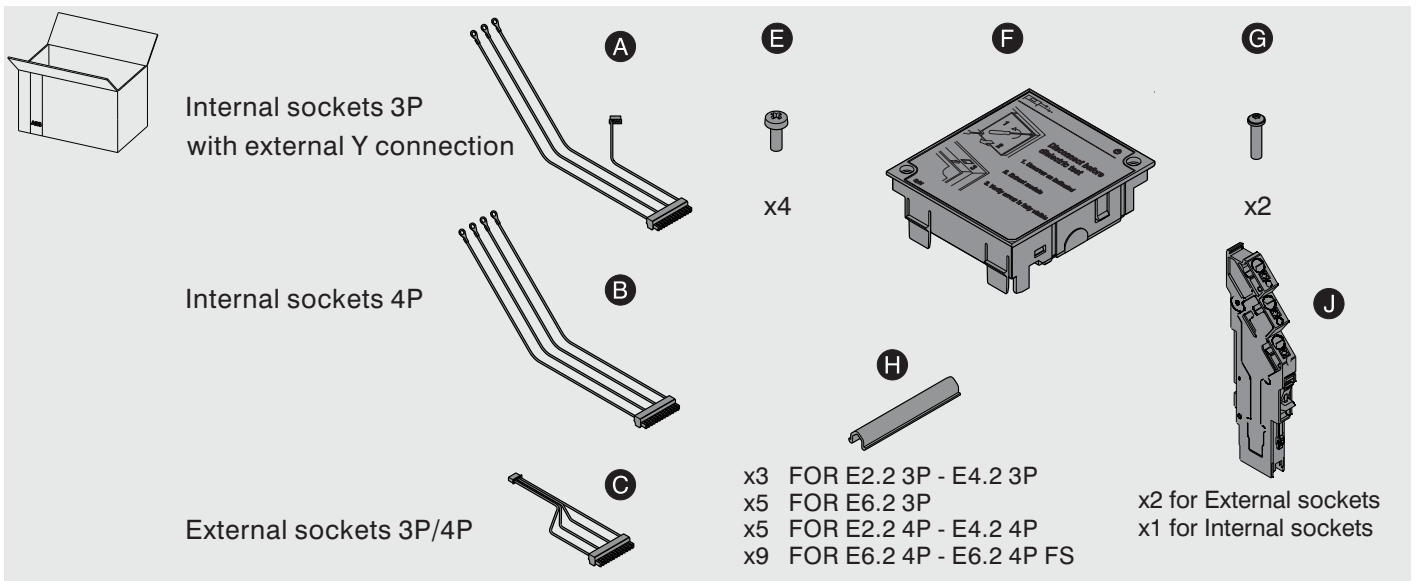
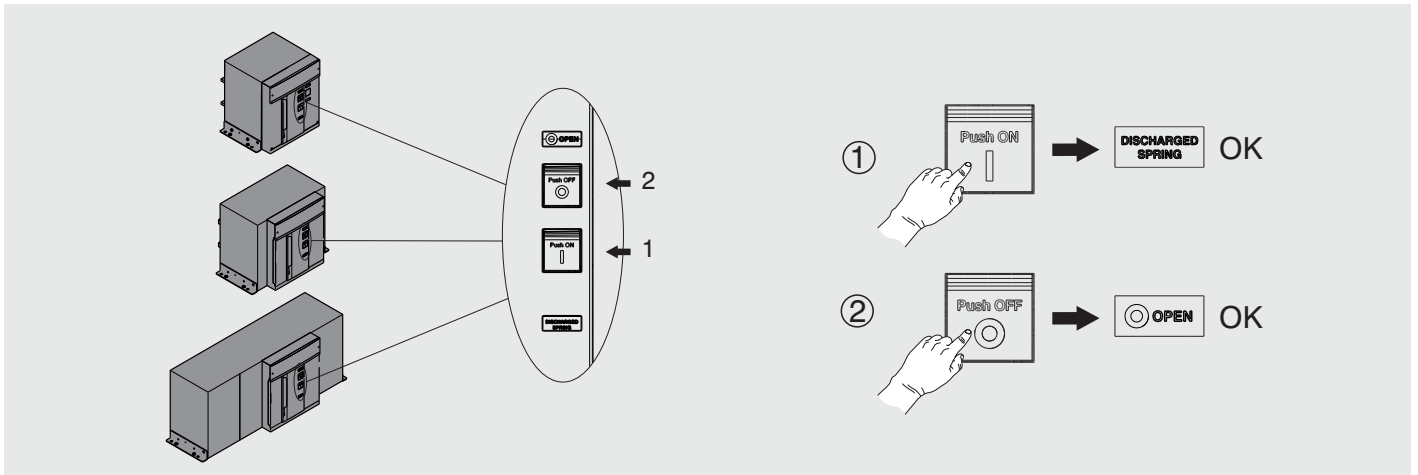

Only with code:
 1SDA076245R1 - E2.2
 1SDA076246R1 - E4.2
 1SDA076257R1 - E6.2
 Voltage socket for neutral on right side

1

Per interventi su interruttori in esecuzione fissa o su parti fisse, togliere tensione al circuito di potenza ed ai circuiti ausiliari, mettere a terra in modo visibile i terminali, sia dal lato alimentazione che dal lato carico. Mettere in sicurezza in base alle norme e leggi vigenti.

If work must be performed on fixed circuit-breakers or on fixed parts, disconnect the power supply to the power circuit and auxiliary circuits and visibly earth the terminals on both the supply side and load side. Put equipment in a safe condition as established by the standards and laws in force.

Für Eingriffe an Leistungsschaltern in der festen Ausführung oder an festen Teilen die Leistungs- und Hilfsstromkreise stromlos schalten und die Anschlüsse sowohl auf der Speise- als auch der Lastseite gut sichtbar erden. Aufgrund der geltenden Normen und gesetzlichen Bestimmungen absichern.

Pour des interventions sur des disjoncteurs en version fixe ou sur des parties fixes, couper la tension au circuit de puissance et aux circuits auxiliaires et mettre à la terre de manière visible les prises aussi bien du côté alimentation que du côté charge. Mettre en sécurité conformément aux normes et aux Lois en vigueur.

Para intervenciones en los interruptores en ejecución fija o en partes fijas, quitar tensión al circuito de potencia y a los circuitos auxiliares y poner a tierra en modo visible los terminales, tanto del lado alimentación como también del lado carga. Poner en seguridad en base a las normas y leyes vigentes.

2

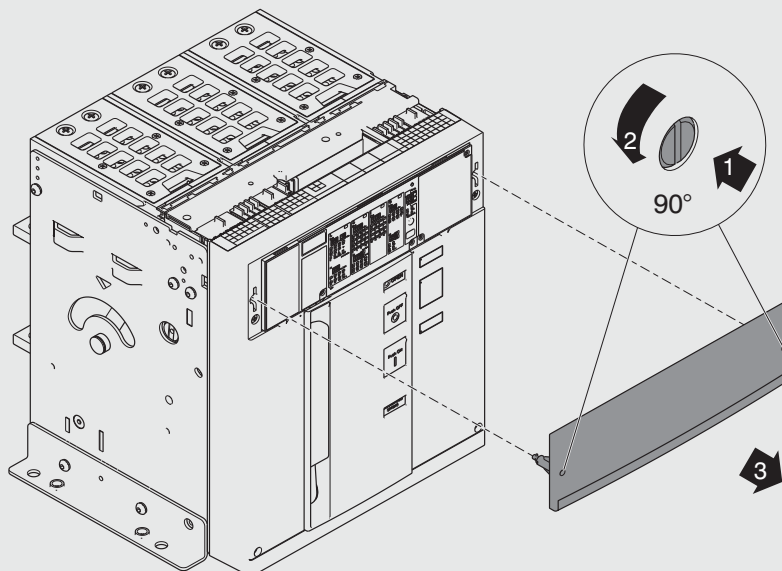

3

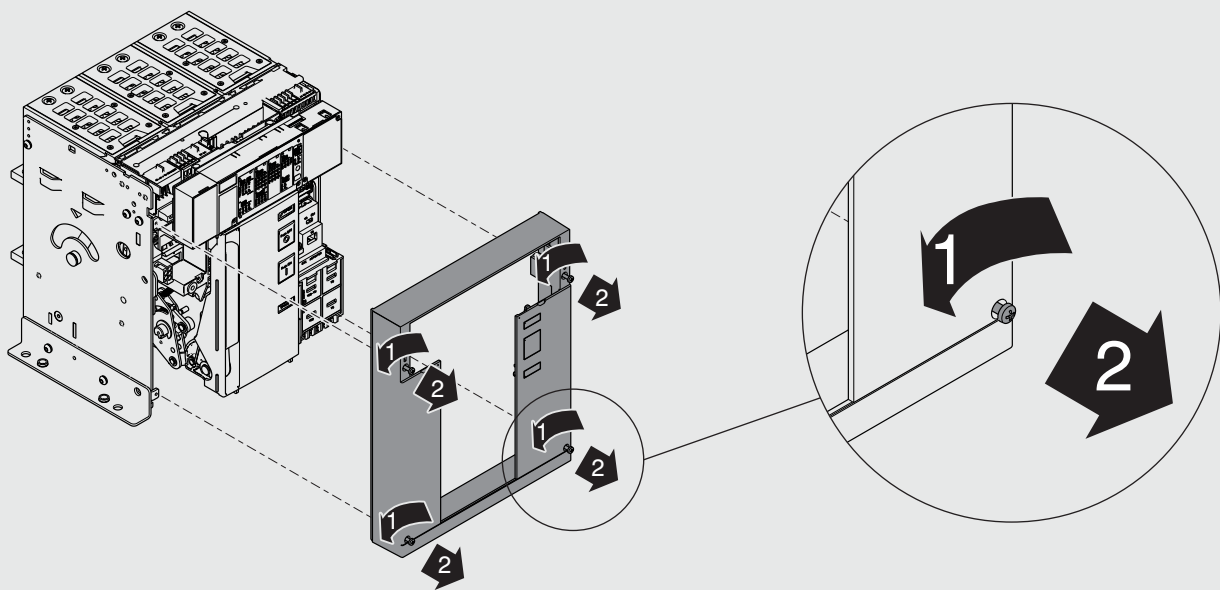

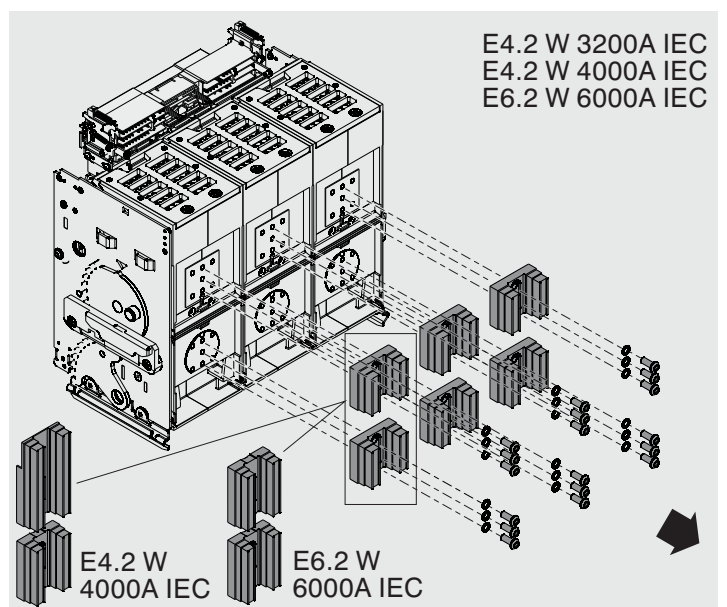
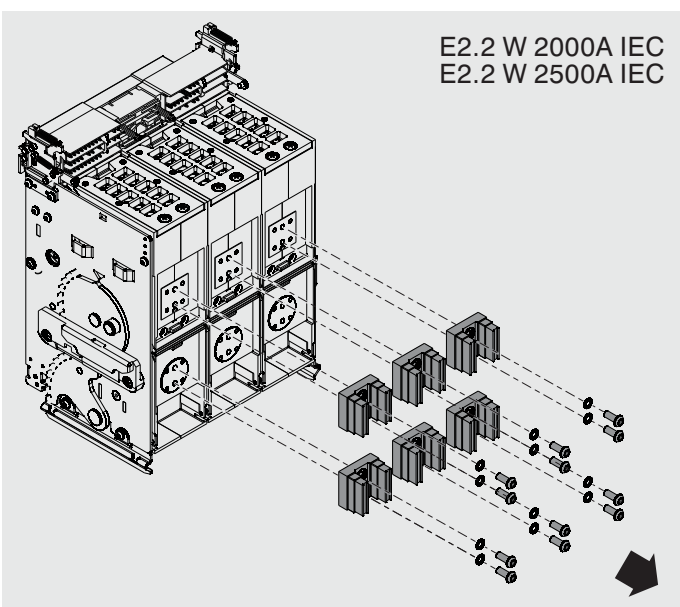
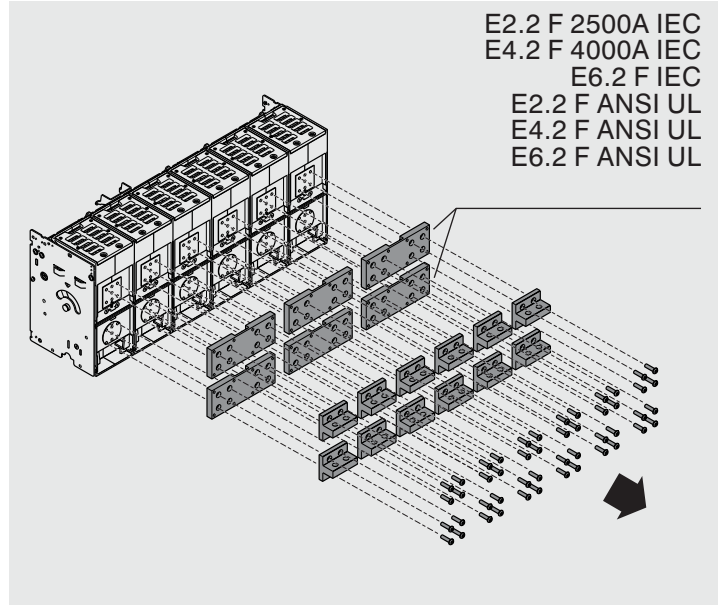
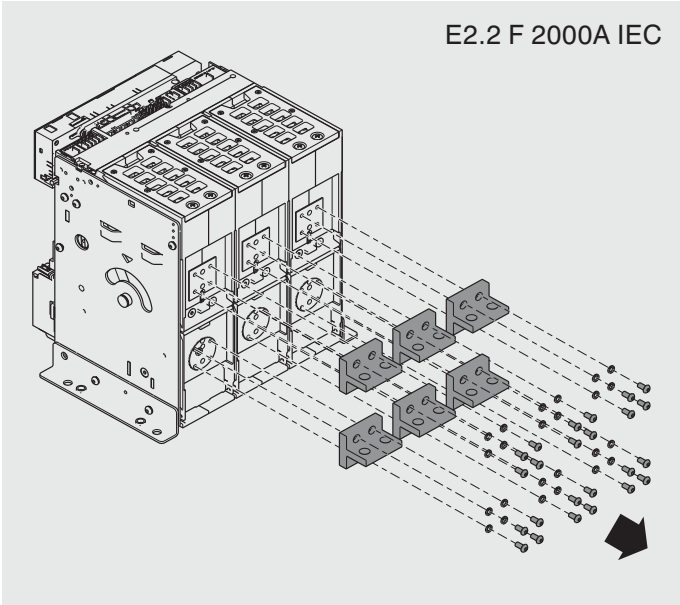
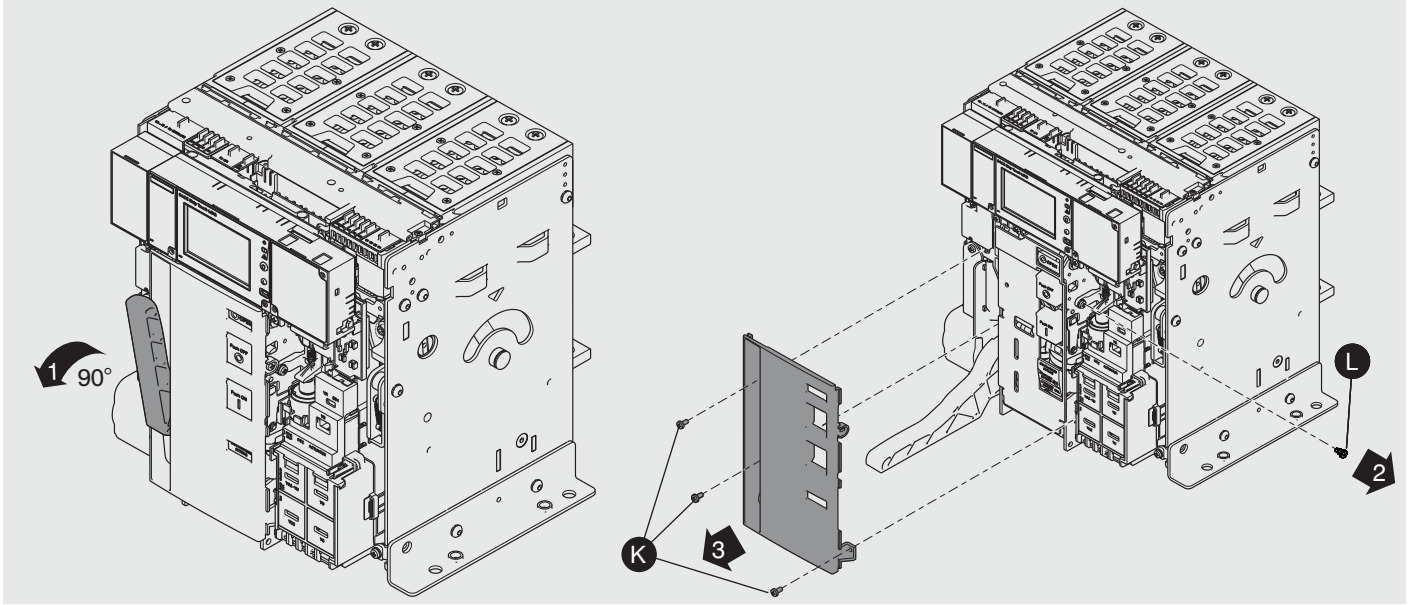

9

E2.2 W 1600A ANSI UL

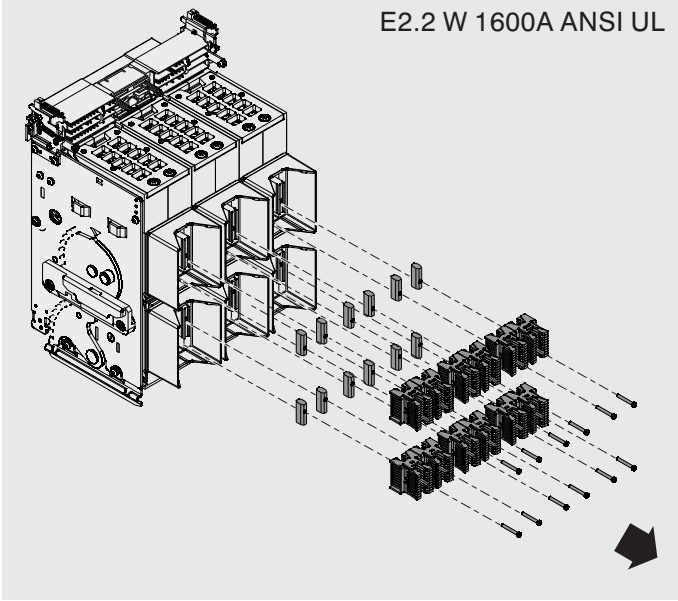

10

E2.2 W 1600A ANSI UL

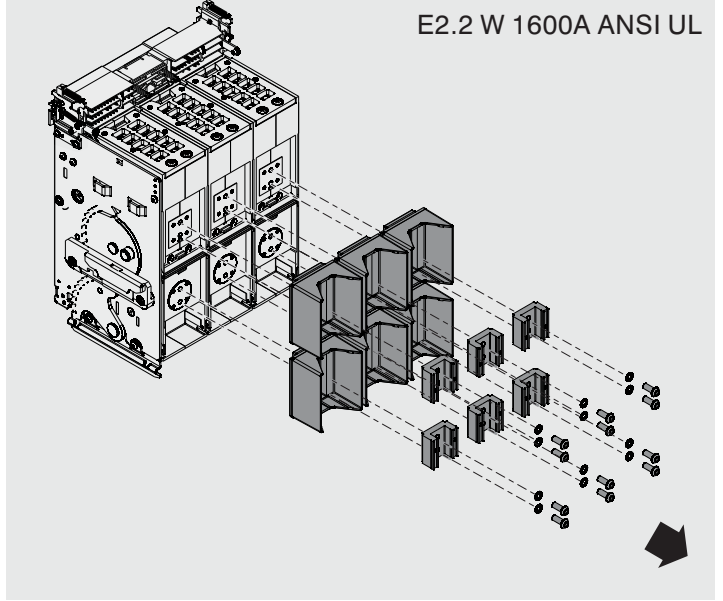

11

E2.2 W 2000A ANSI UL

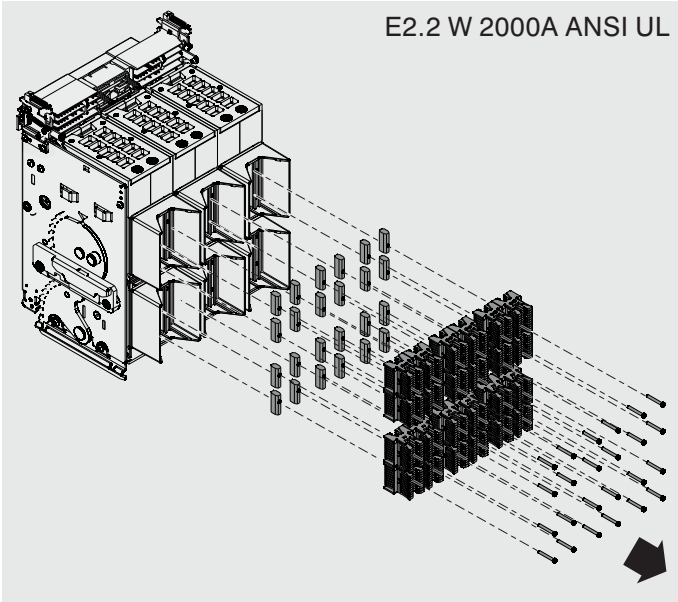

12

E2.2 W 2000A ANSI UL

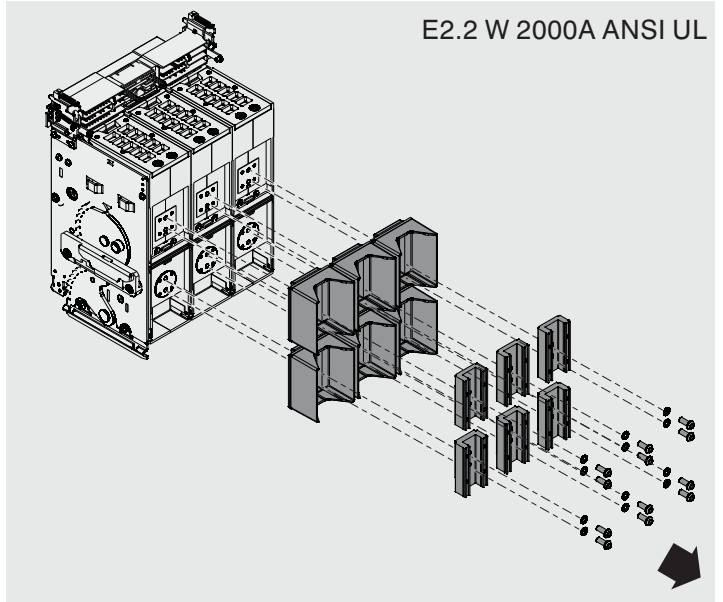

13

E4.2 W 2500A ANSI UL
E4.2 W 3200A ANSI UL

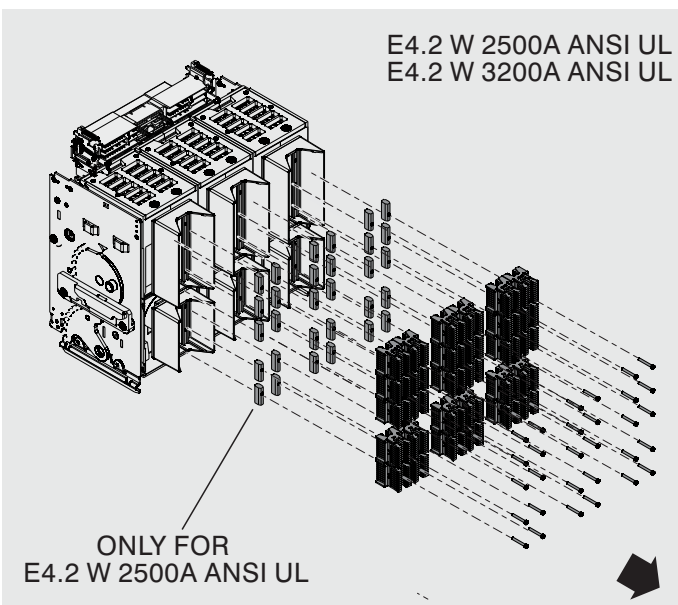

14

E4.2 W 2500A ANSI UL
E4.2 W 3200A ANSI UL

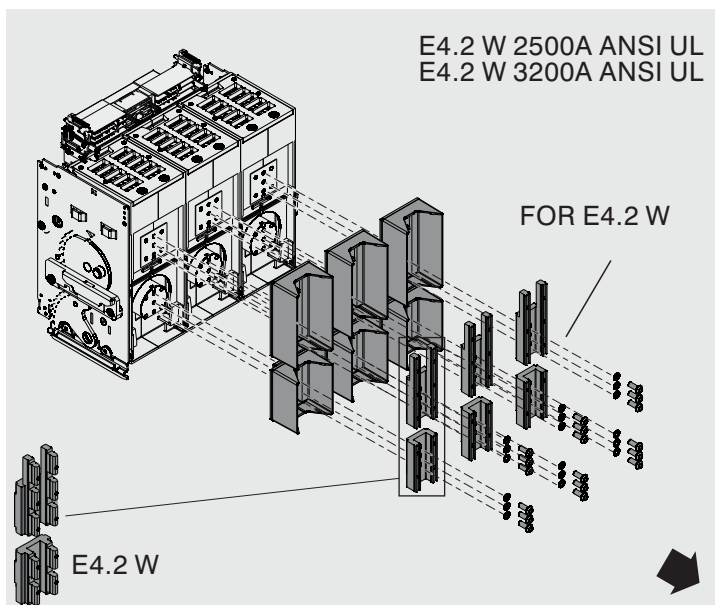

15

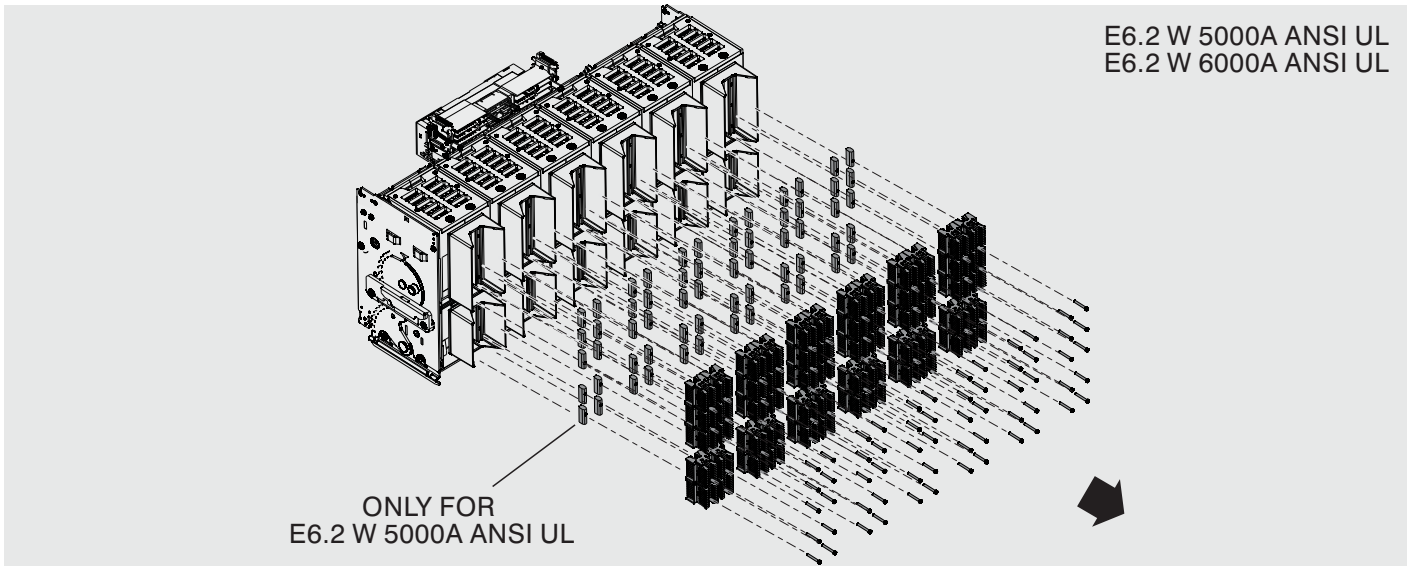

16

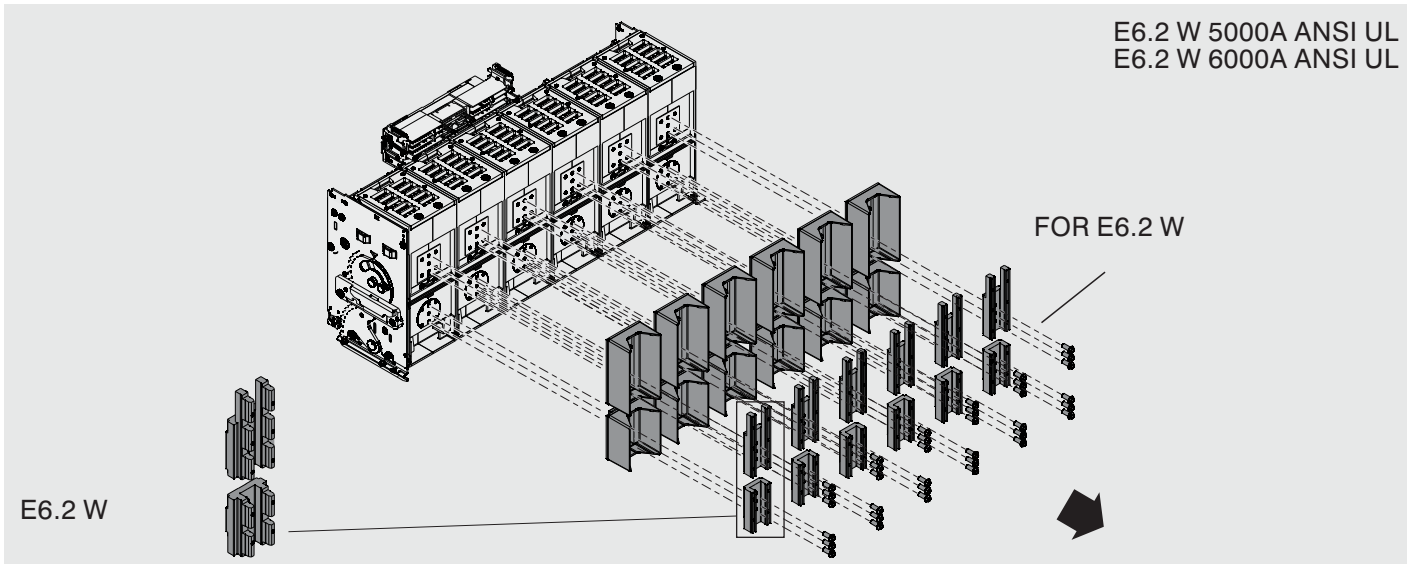

17

Example for E2.2-E4.2 F III

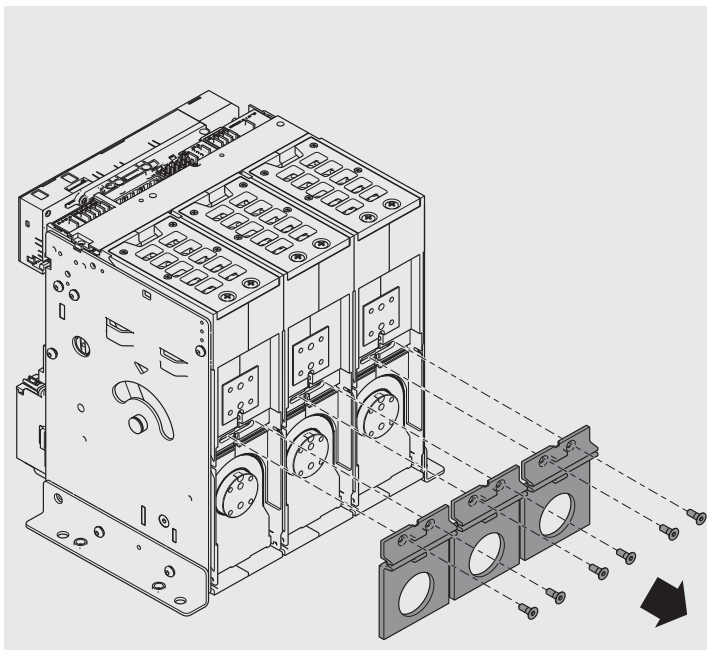

18

E2.2-E4.2-E6.2 F

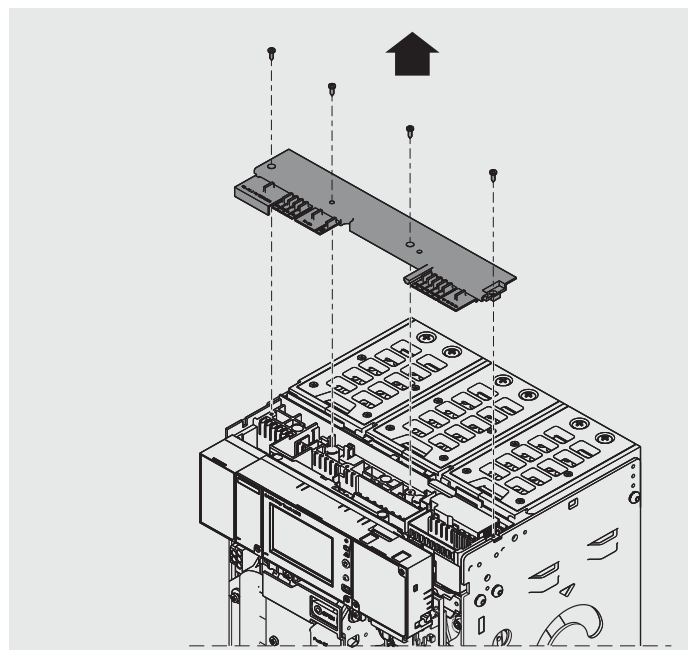

19

E2.2-E4.2-E6.2 W

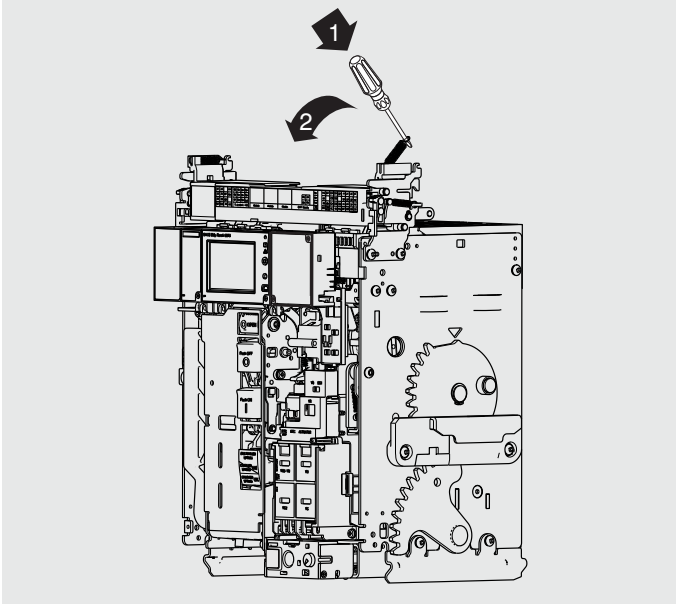

20

E2.2-E4.2-E6.2 W

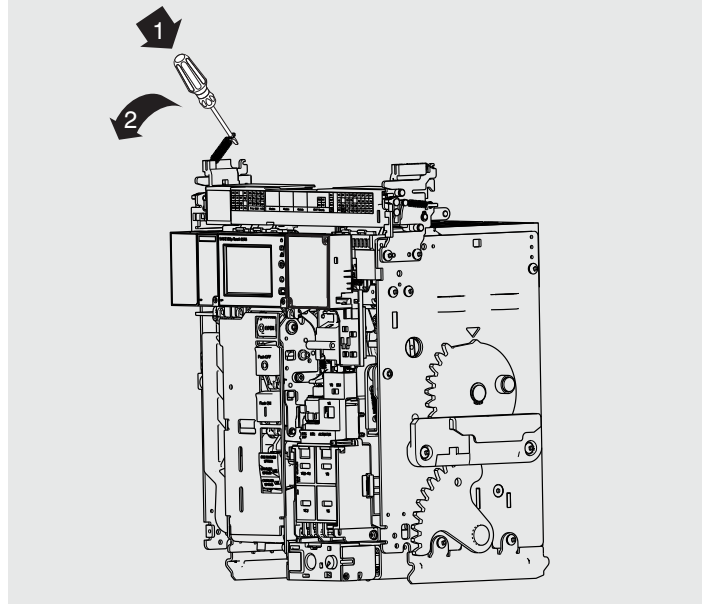

21

E2.2-E4.2-E6.2 W

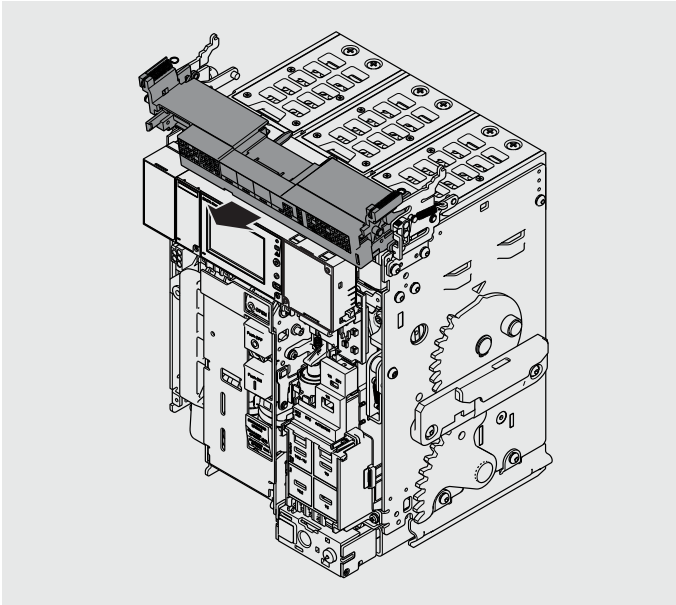

22

E2.2-E4.2-E6.2 W

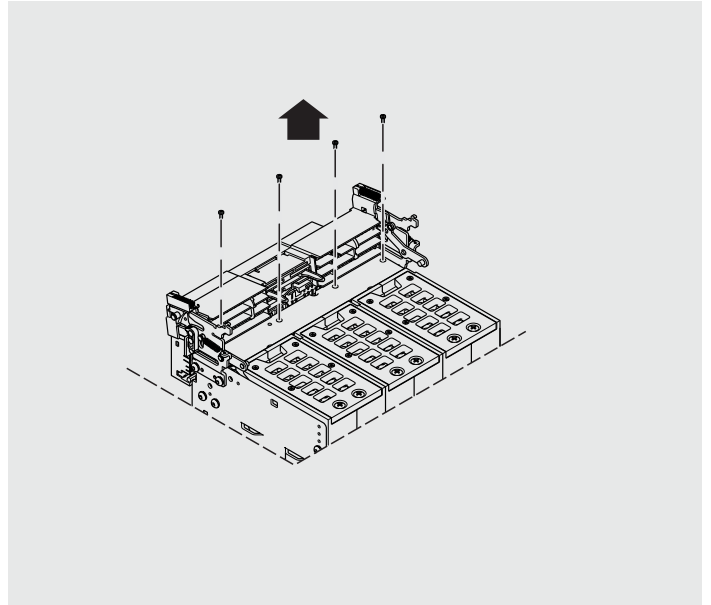

23

E2.2-E4.2-E6.2 W

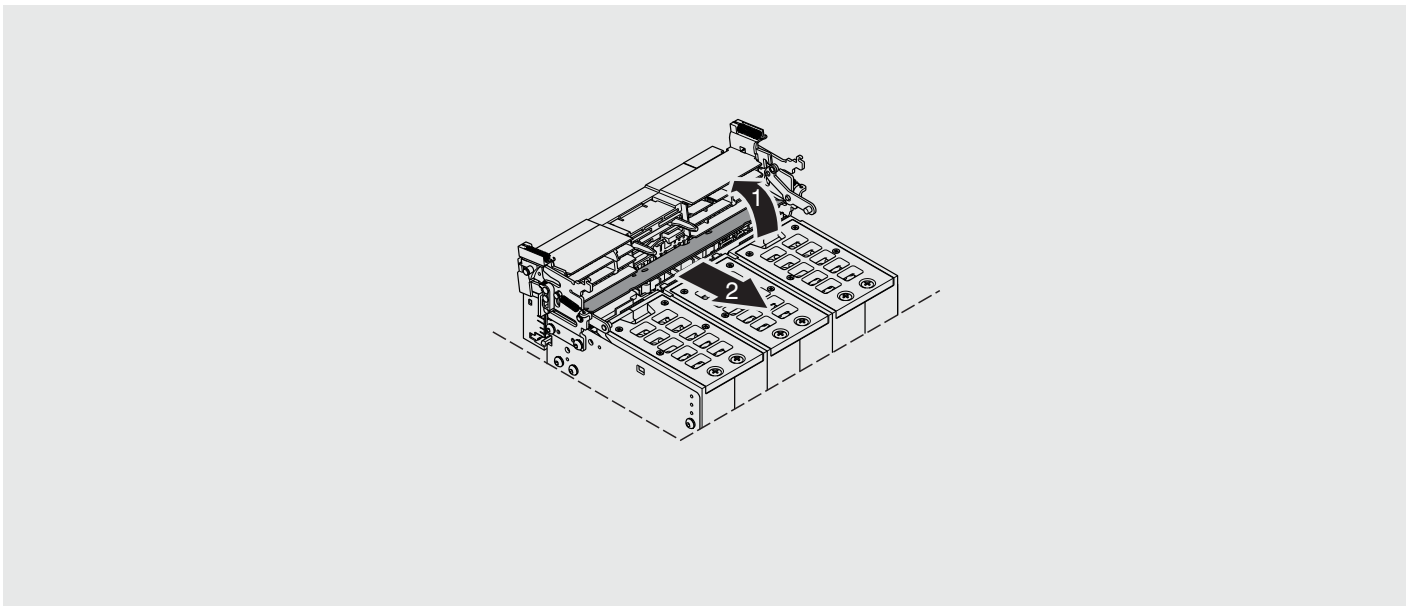

Per la sequenza di smontaggio della mainboard e dei contatti striscianti (versione estraibile) consultare il foglio kit 1SDH001000R0523.

For the mainboard and sliding contacts (withdrawable version) disassembling sequence refer to the instructions sheet 1SDH001000R0523.

Für die Ausbausequenz des Mainboard und Gleitkontakte (ausfahrbare Version) siehe das Blatt des Bausatzes 1SDH001000R0523.

Pour la séquence de démontage de mainboard et frotteurs (version débrochable) consulter la notice d'instructions 1SDH001000R0523.

Para la secuencia de desmontaje de mainboard y contactos deslizantes (versión extraíble) consulte las instrucciones 1SDH001000R0523.

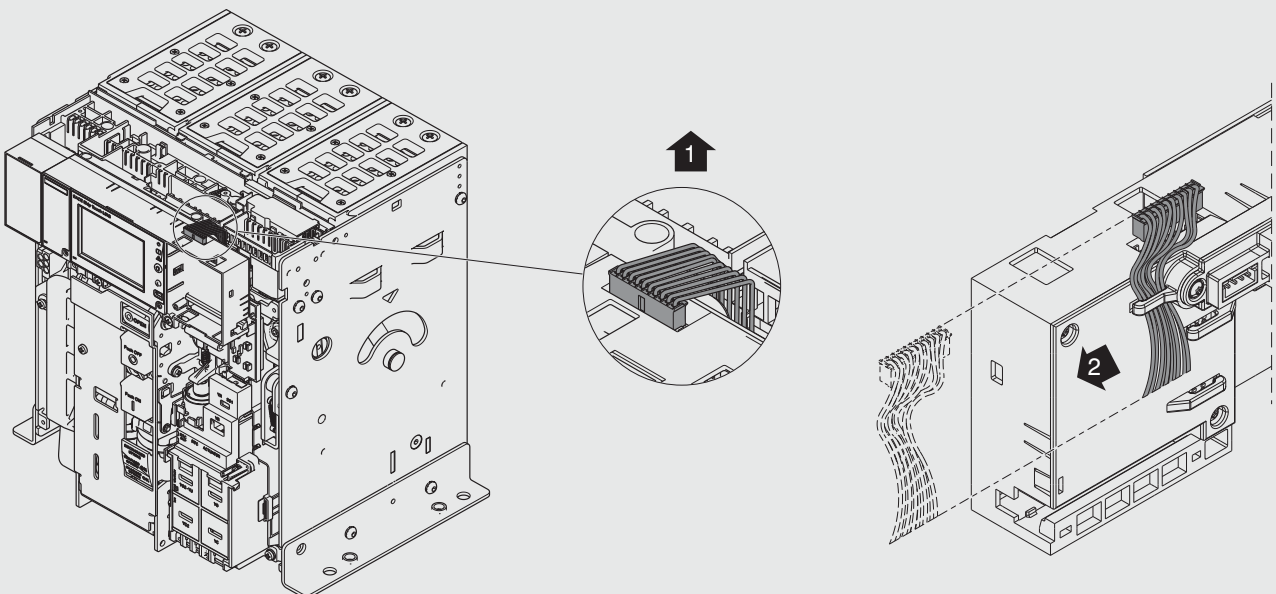
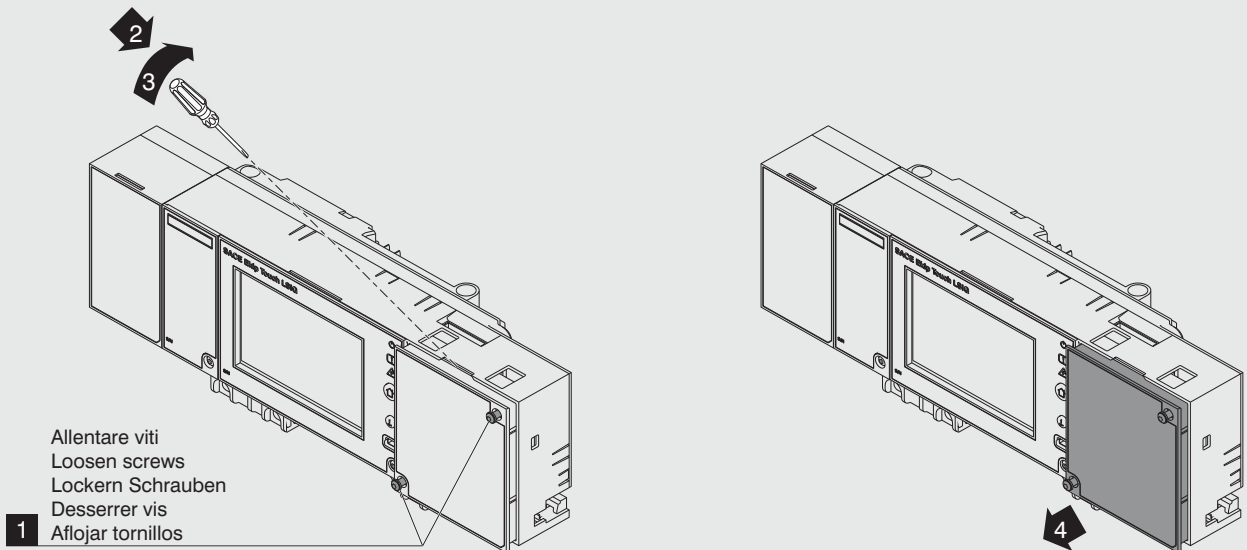

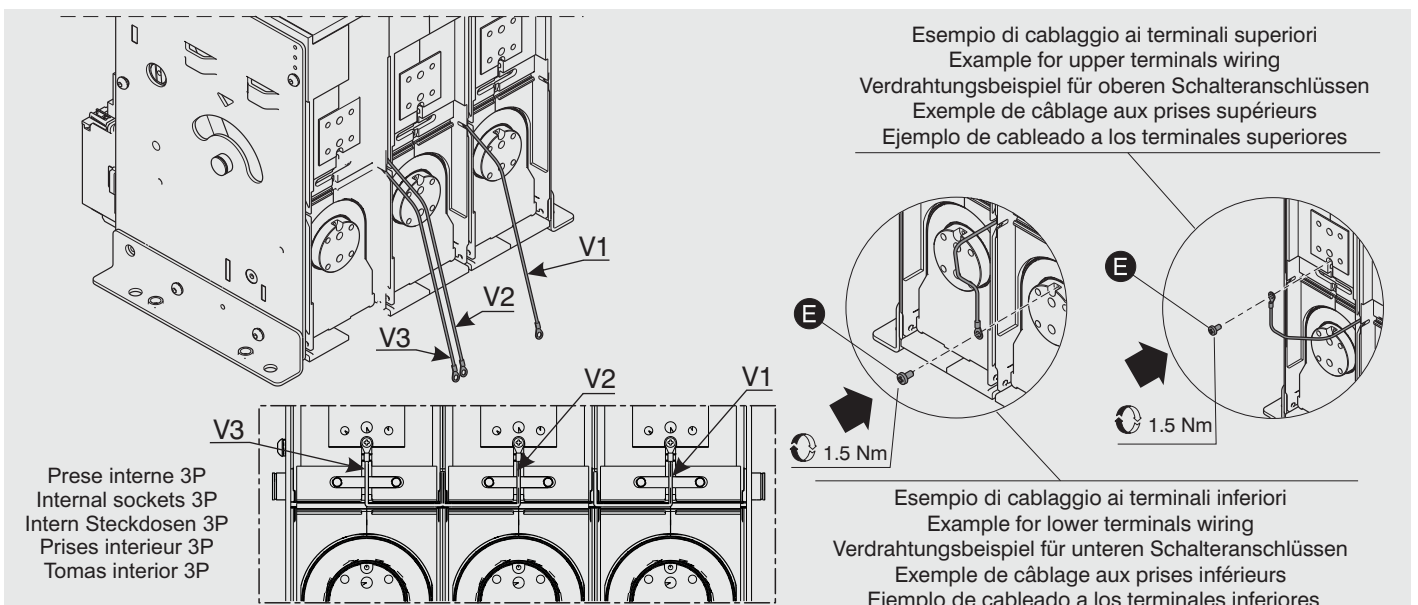
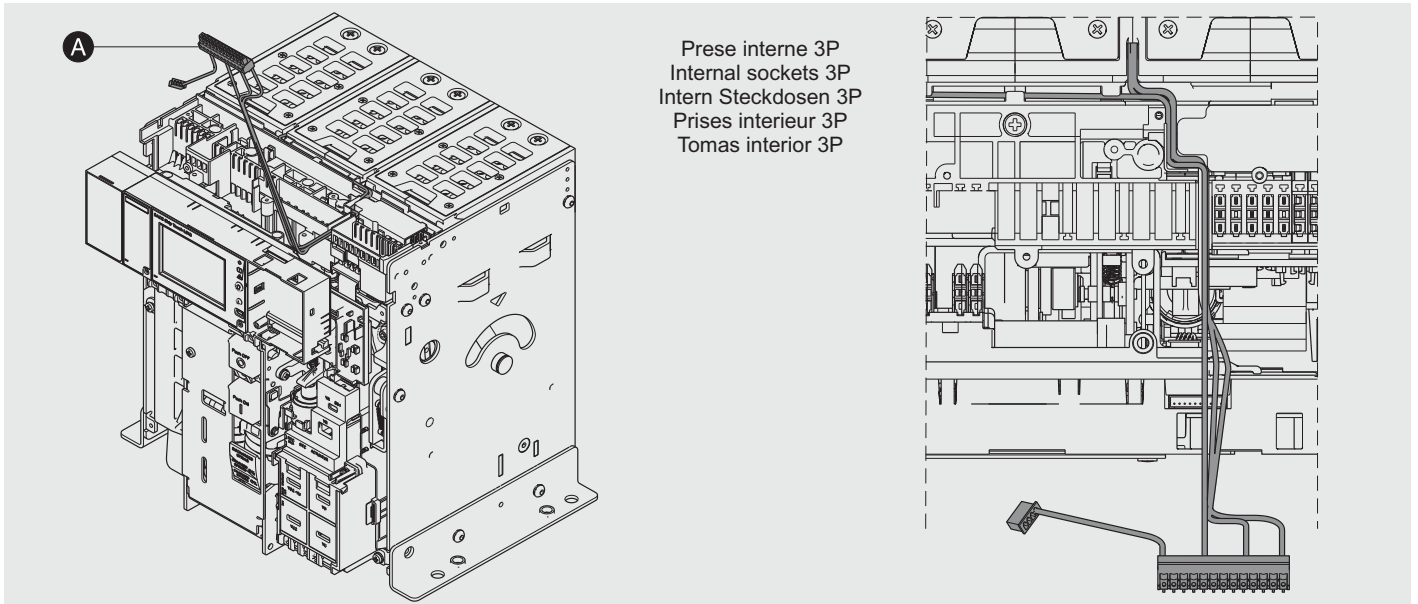
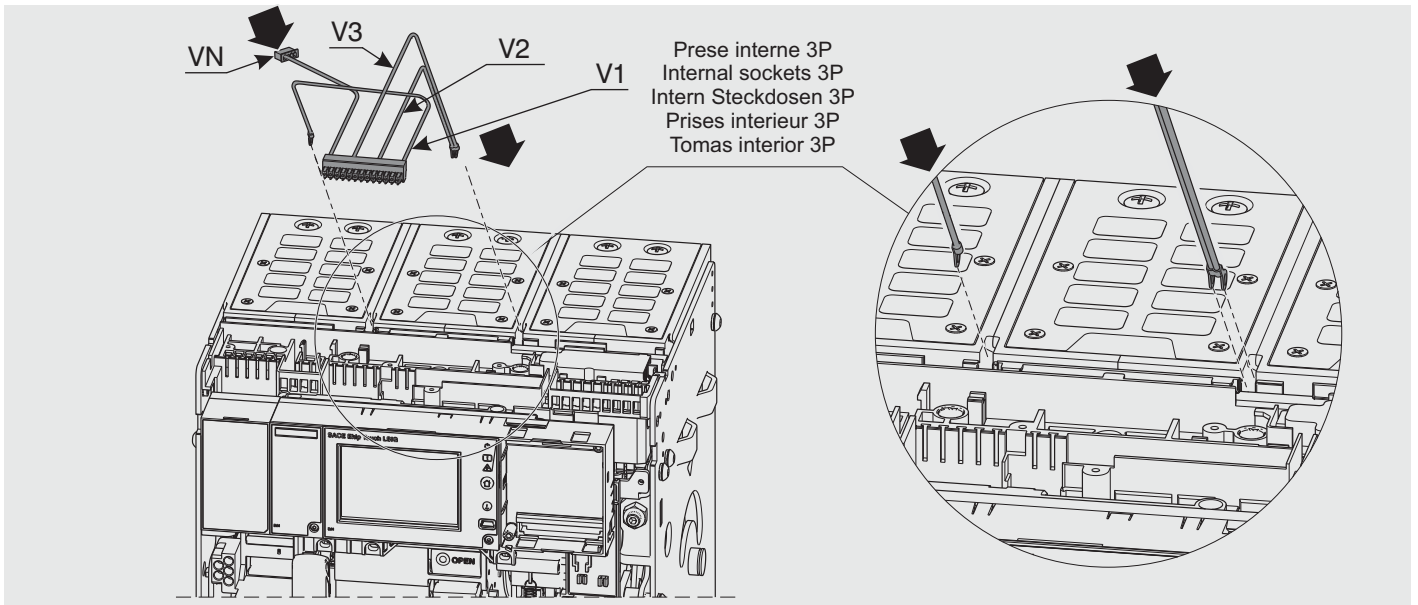

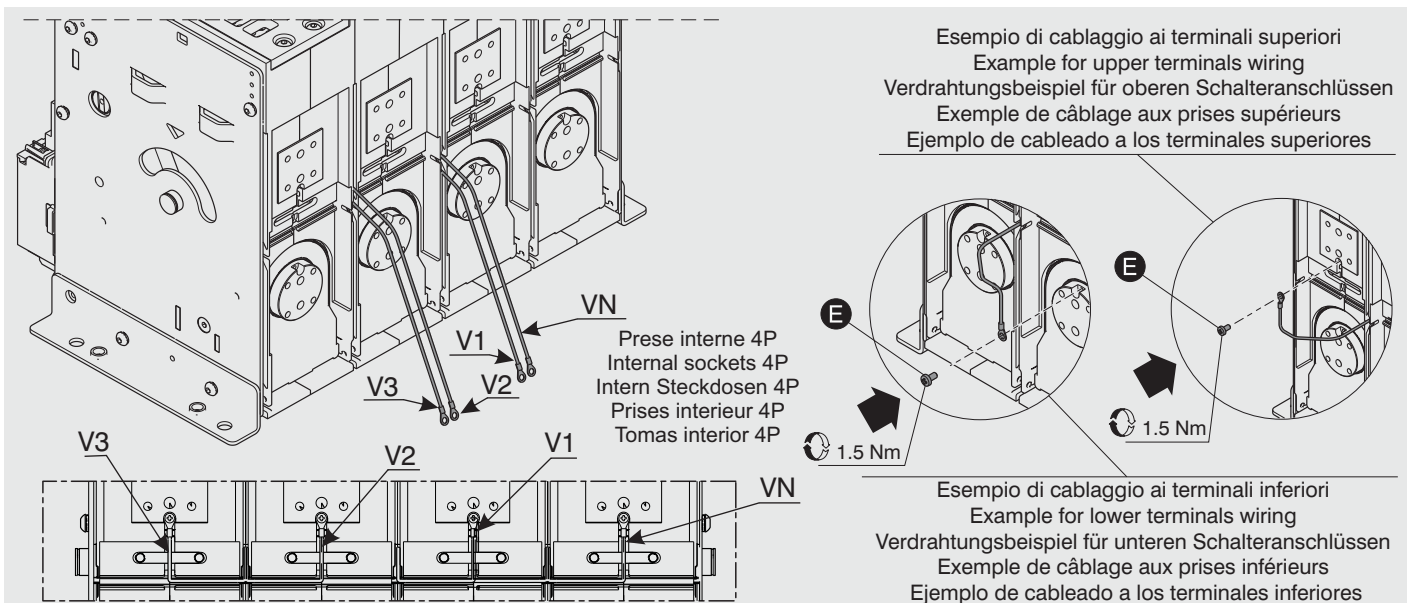
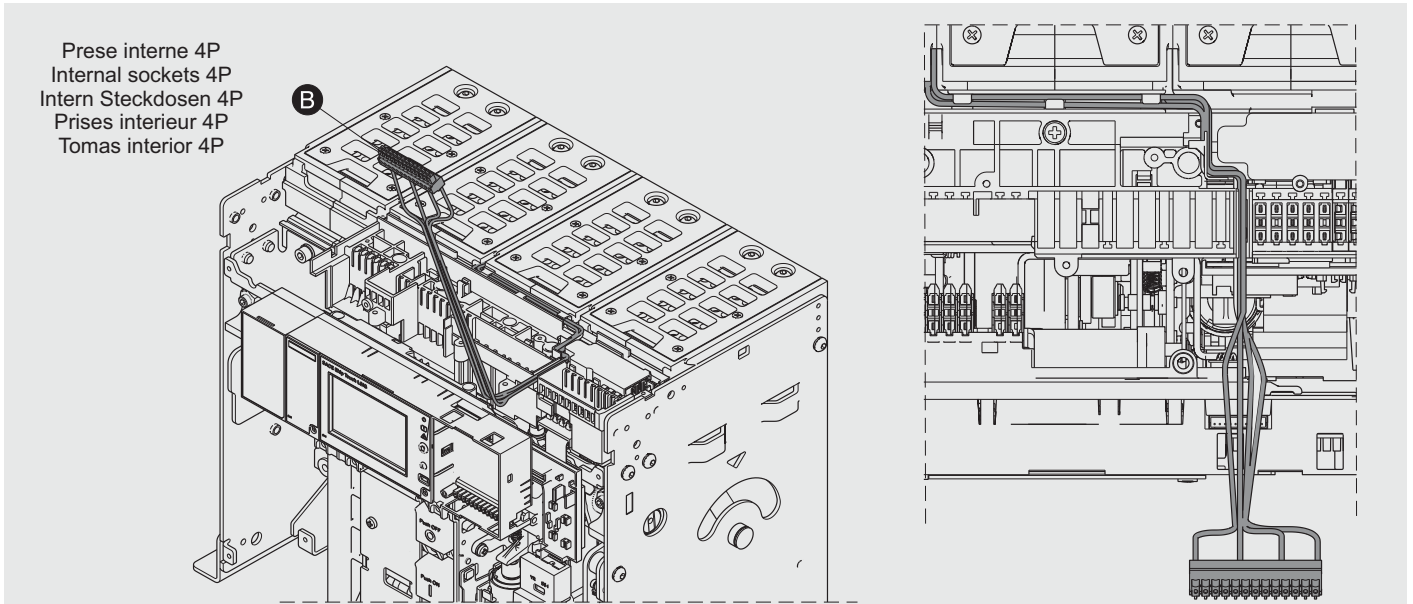
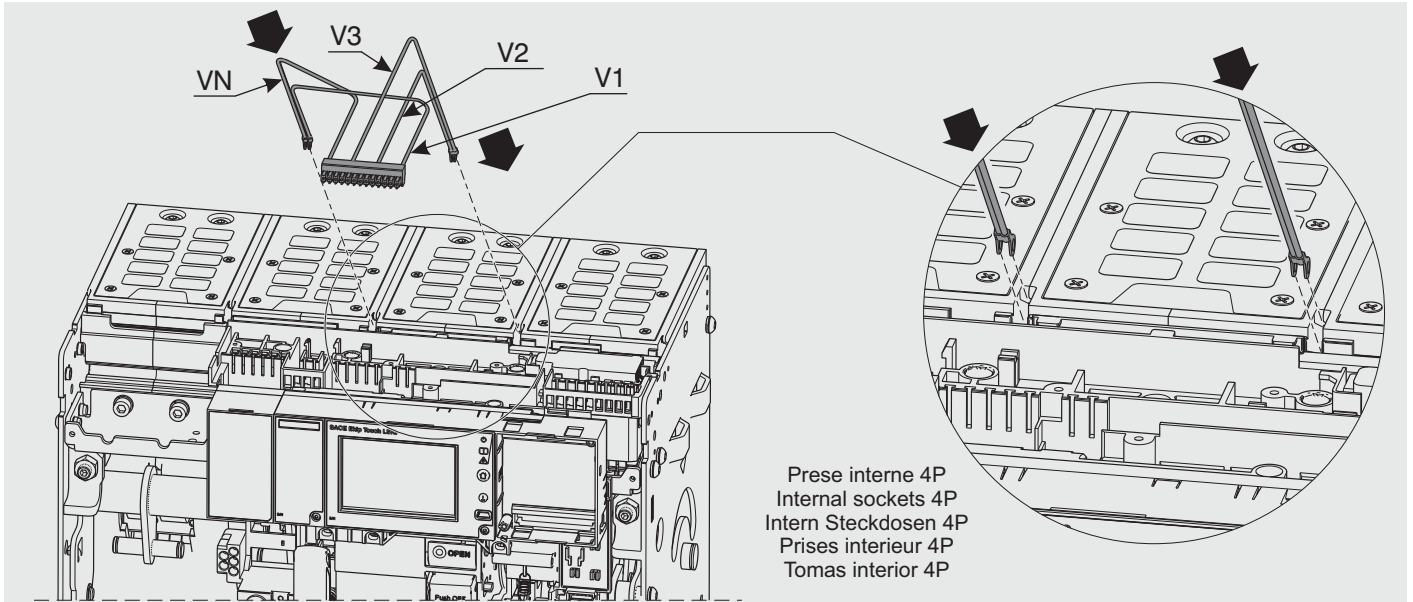

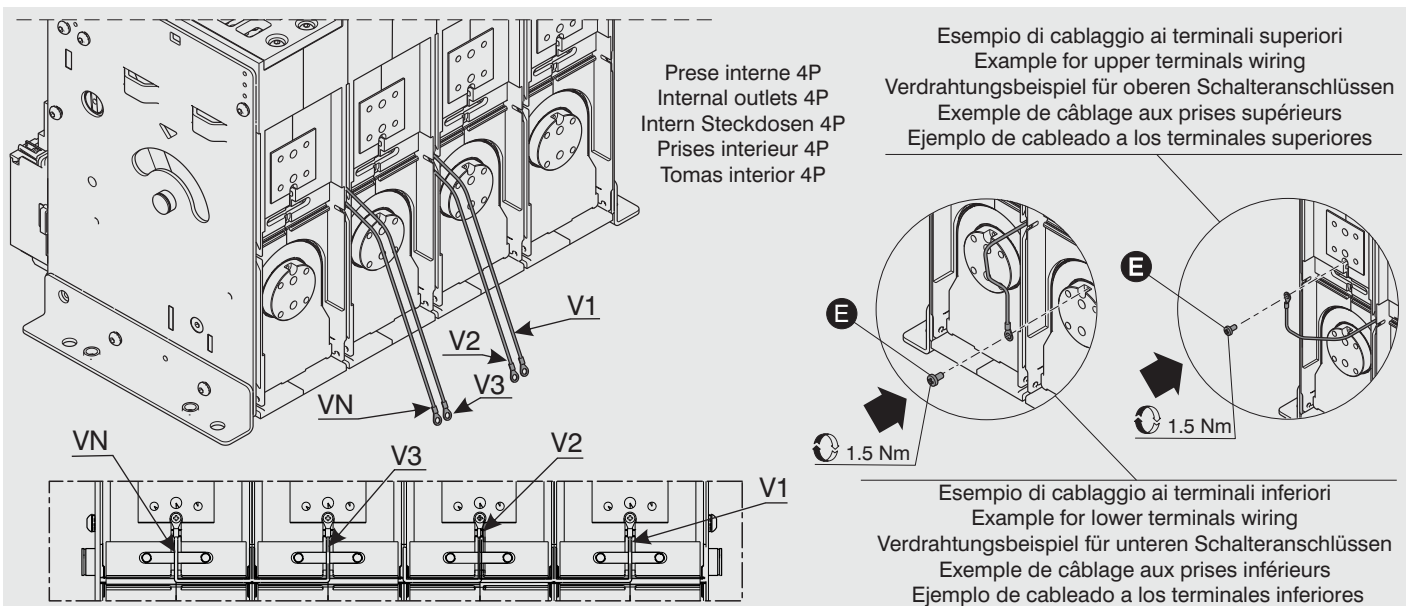
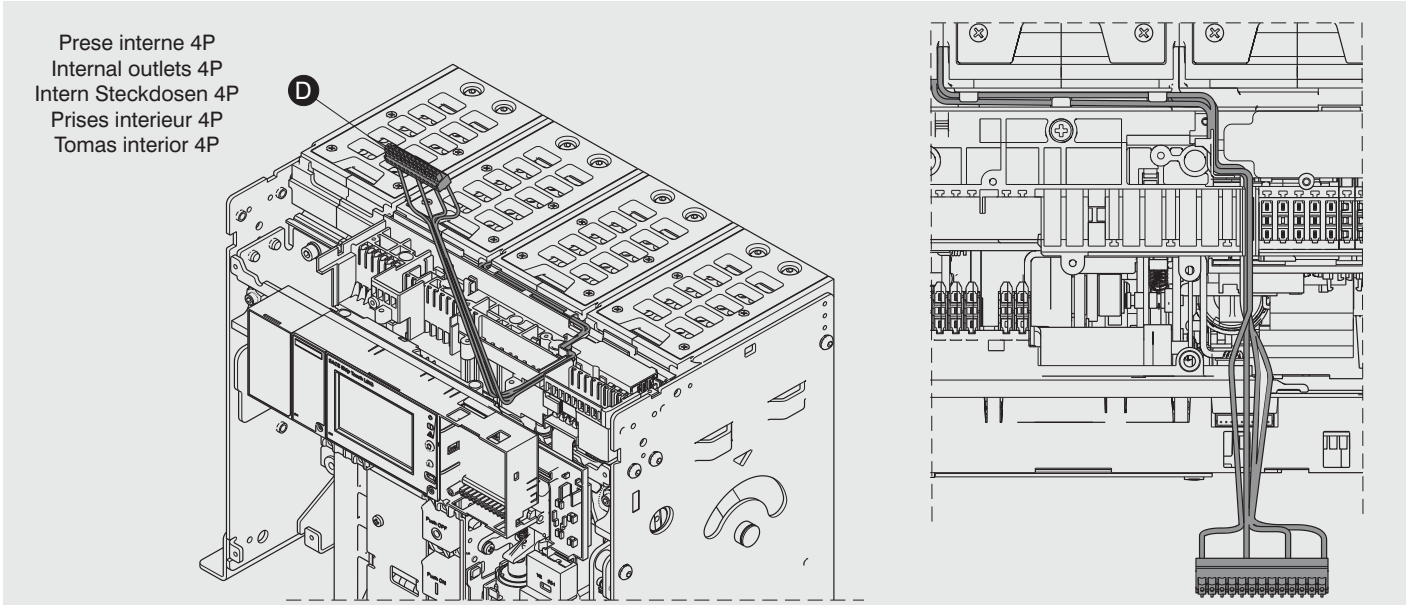
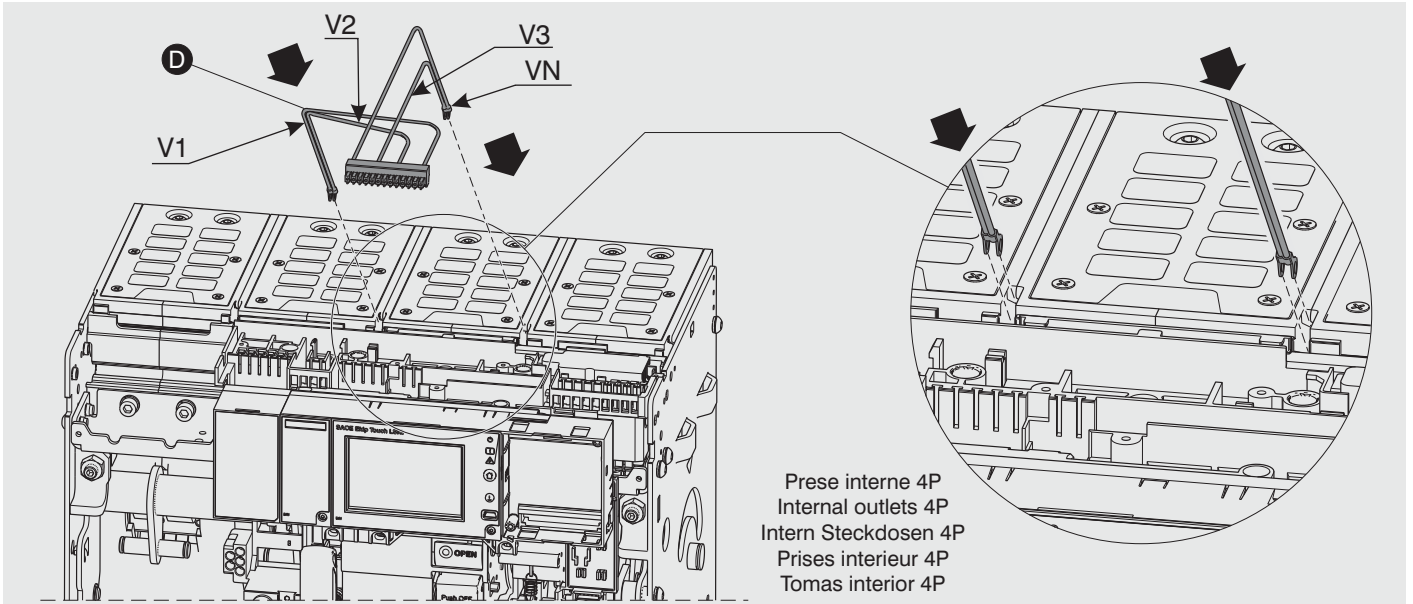

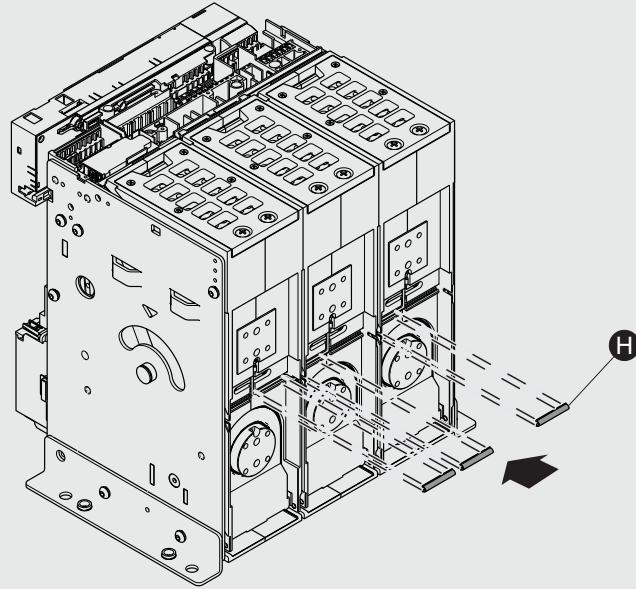

Esempi per connessioni superiori, validi anche per connessioni inferiori.
 Example for upper connections, valid for lower connections too.
 Beispiel für oberen Verbindungen, Gilt auch für unteren Verbindungen.
 Exemple pour connexions supérieures, valable aussi pour connexions inférieures.
 Ejemplo para conexiones superiores, válido también para conexiones inferiores.

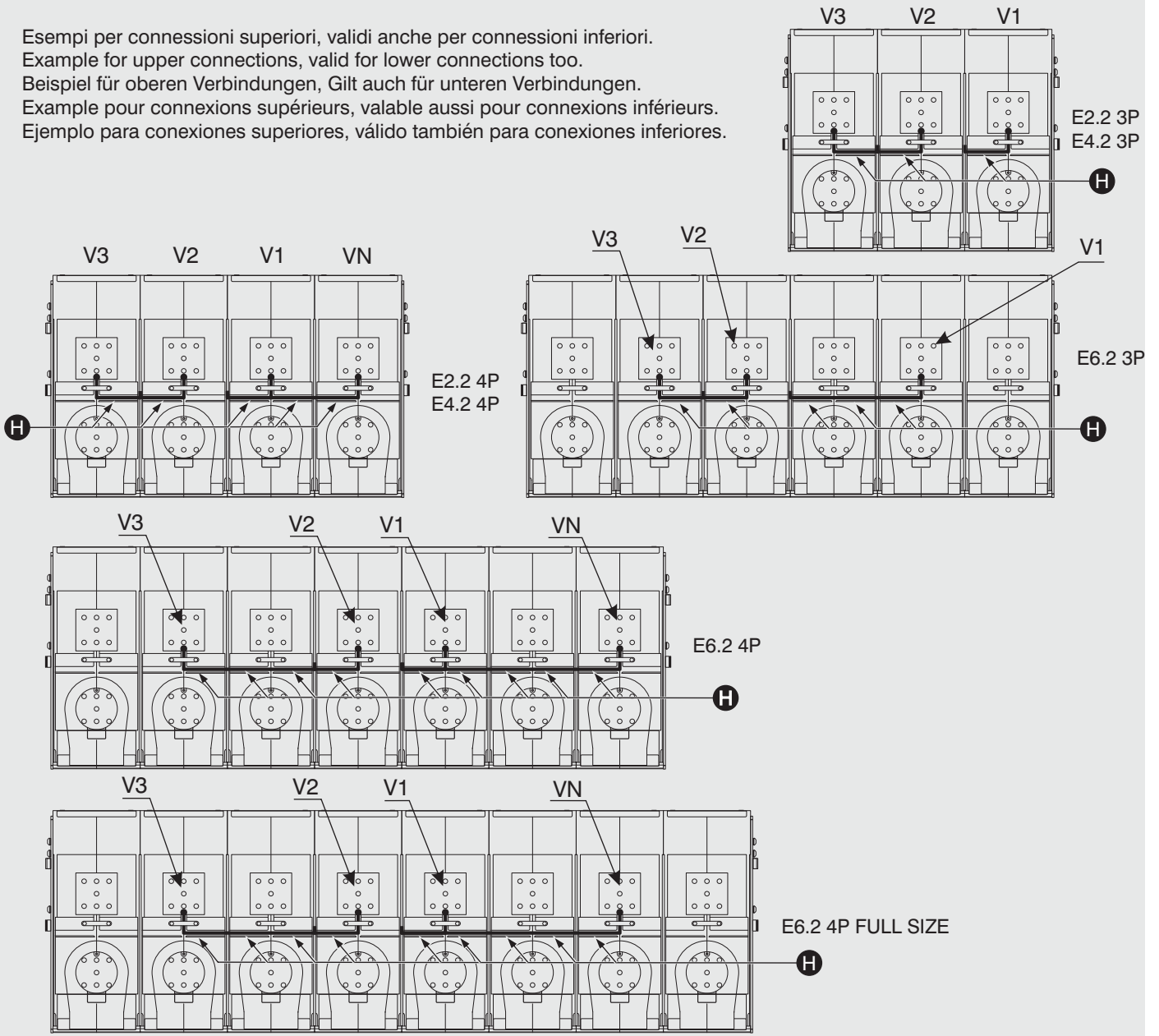

38

Prese interne 3P
Internal outlets 3P
Intern Steckdosen 3P
Prises interieur 3P
Tomas interior 3P

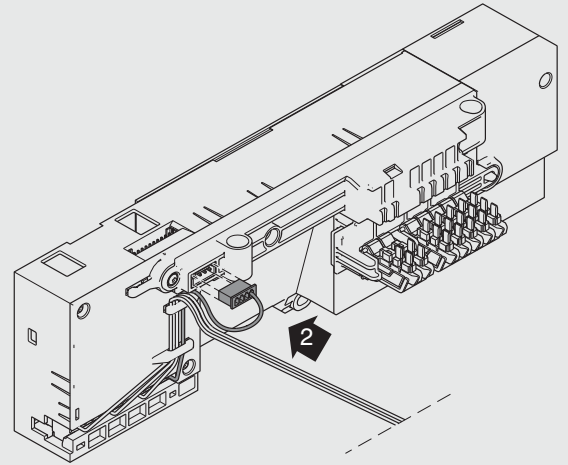
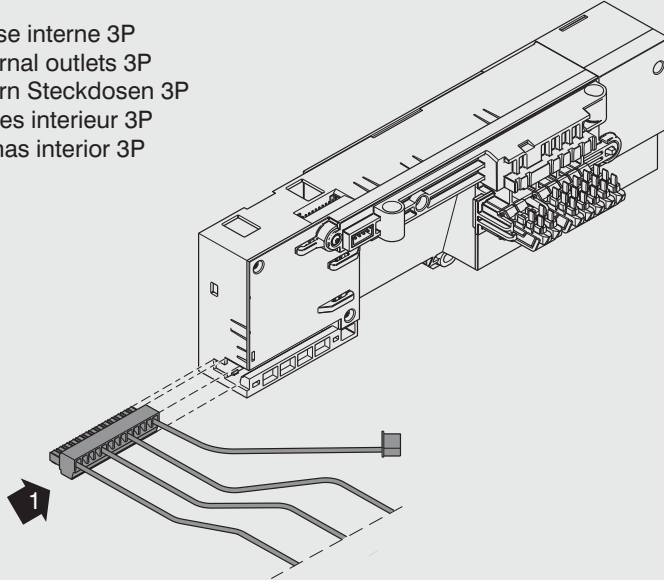

39

Prese interne 4P
Internal outlets 4P
Intern Steckdosen 4P
Prises interieur 4P
Tomas interior 4P

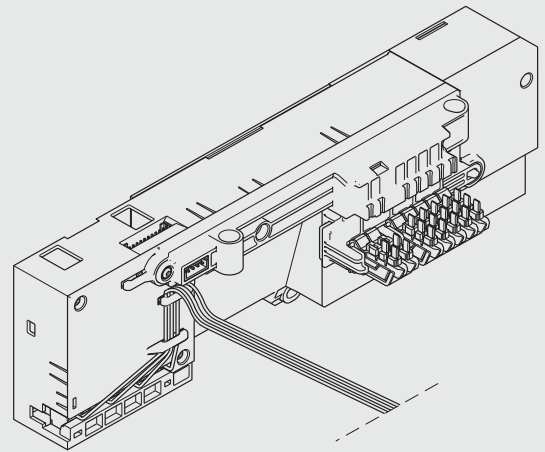
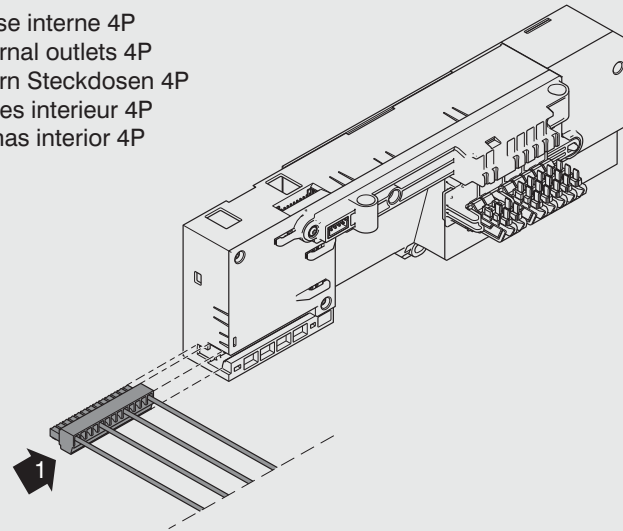

40

Prese esterne 3P/4P
External outlets 3P/4P
Externer Steckdosen 3P/4P
Prises extérieures 3P/4P
Tomas externas 3P/4P

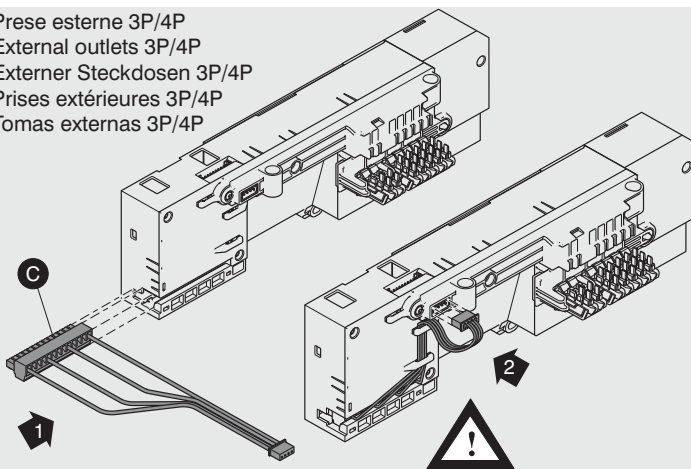

Gli interruttori /E9, /E10, /E12, possono utilizzare solo le prese esterne
Circuit breakers /E9, /E10, /E12, can only use the external outlets
Leistungshalter /E9, /E10, /E12, können nur externe Steckdosen verwenden
Les interrupteurs /E9, /E10, /E12, ne peuvent utiliser que des prises extérieures
Interrupidores /E9, /E10, /E12, sólo pueden utilizar tomas externas

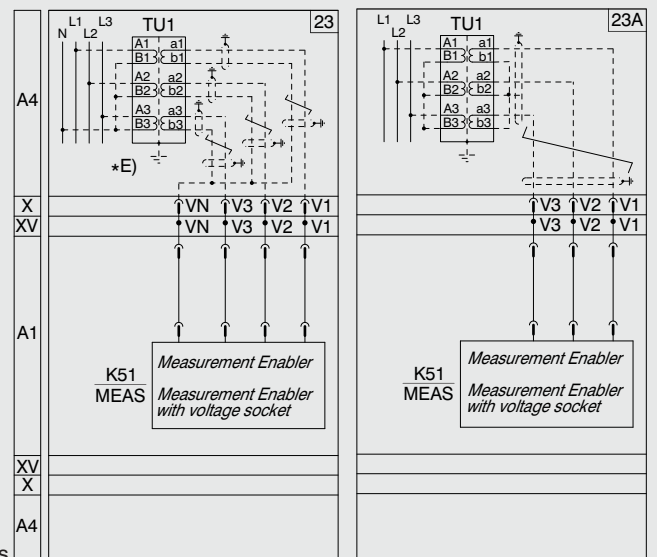

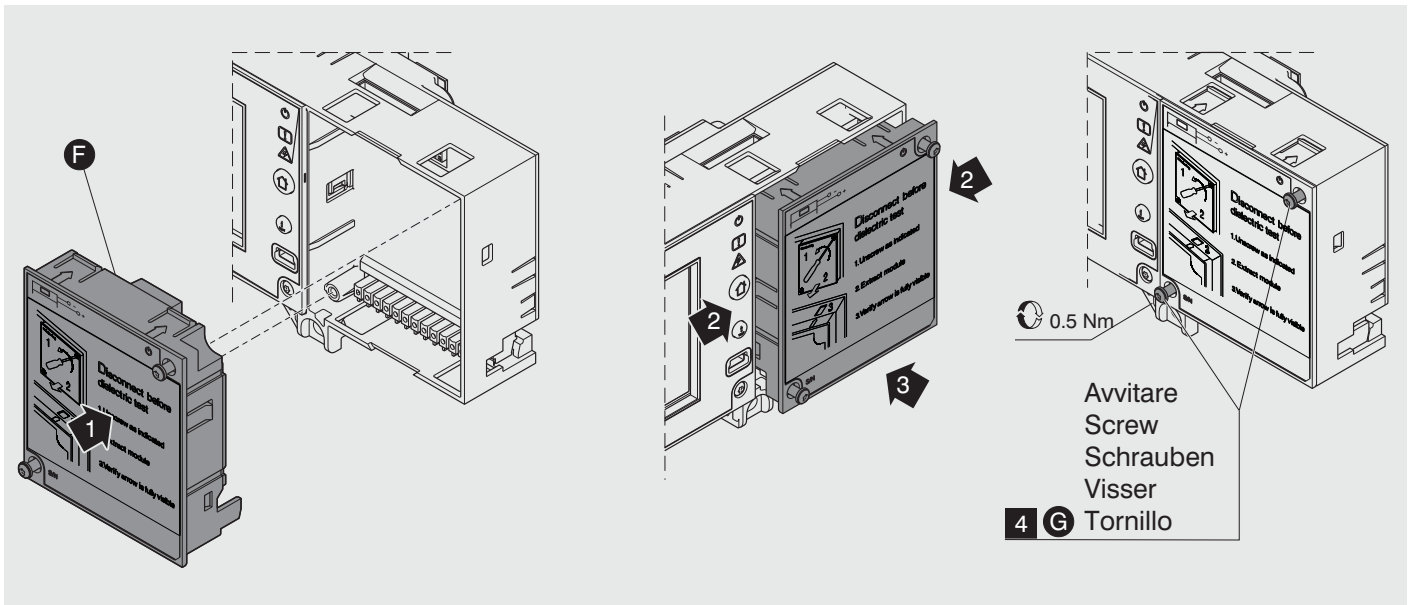

Per la sequenza di montaggio della mainboard e dei contatti striscianti (versione estraibile) consultare il foglio kit 1SDH001000R0523.

For the mainboard and sliding contacts (withdrawable version) assembling sequence refer to the instructions sheet 1SDH001000R0523.

Für die Ausbausequenz des Mainboard und Gleitkontakte (ausfahrbare Version) siehe das Blatt des Bausatzes 1SDH001000R0523.

Pour la séquence de montage de mainboard et frotteurs (version débrochable) consulter la notice d'instructions 1SDH001000R0523.

Para la secuencia de montaje de mainboard y contactos deslizantes (versión extraíble) consulte las instrucciones 1SDH001000R0523.

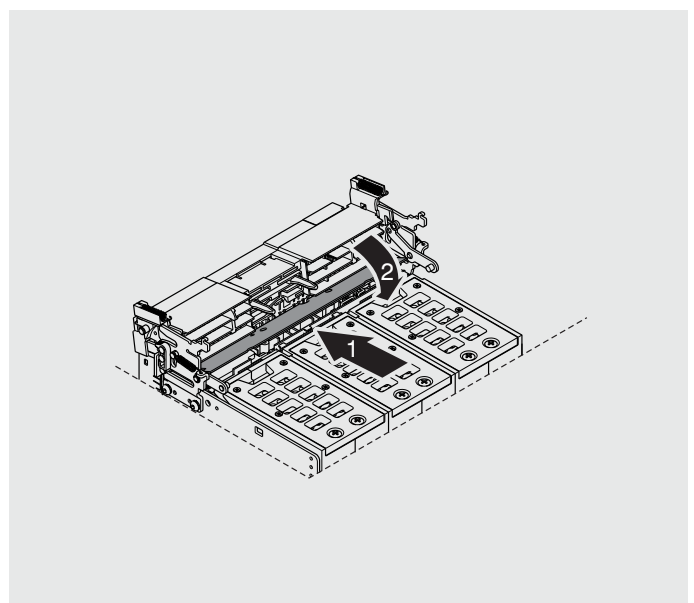
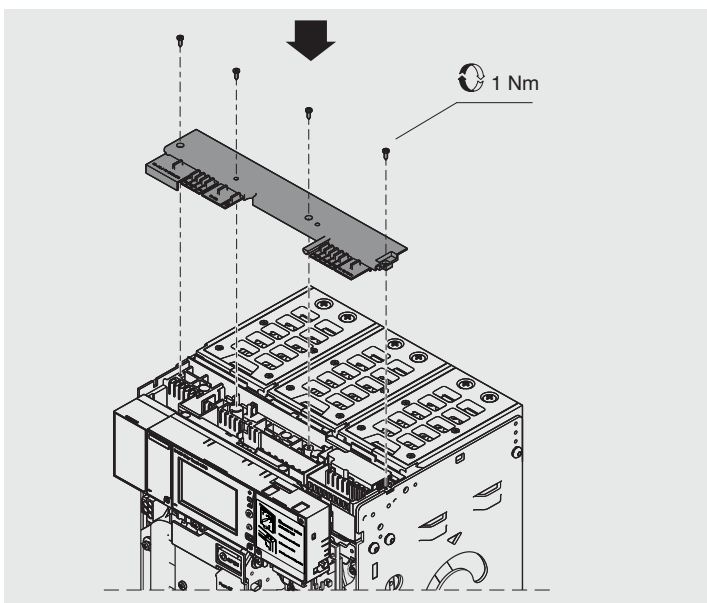

45

E2.2-E4.2-E6.2 W

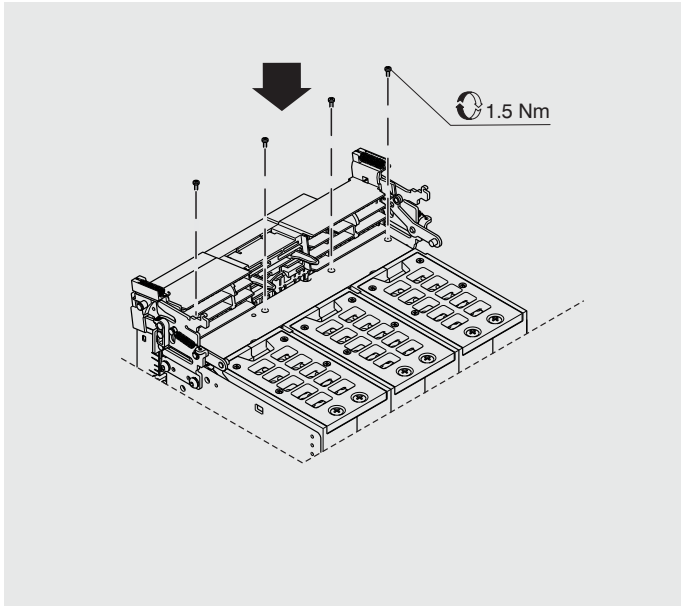

46

E2.2-E4.2-E6.2 W

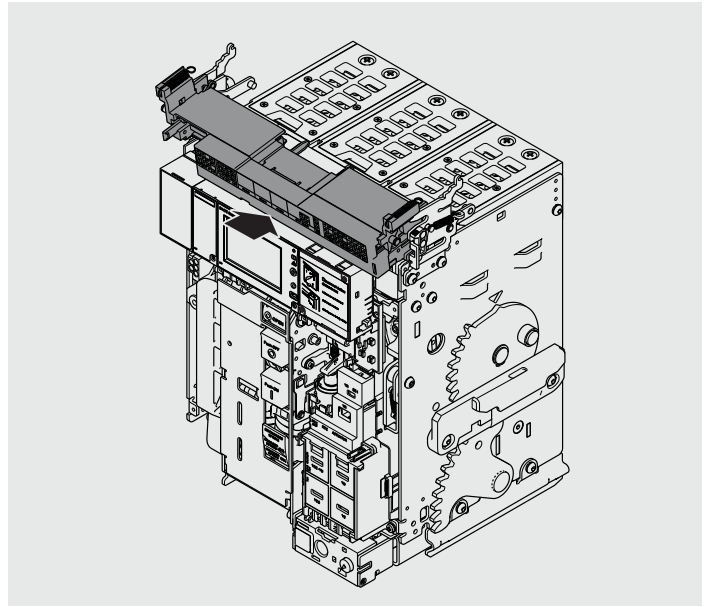

47

E2.2-E4.2-E6.2 W

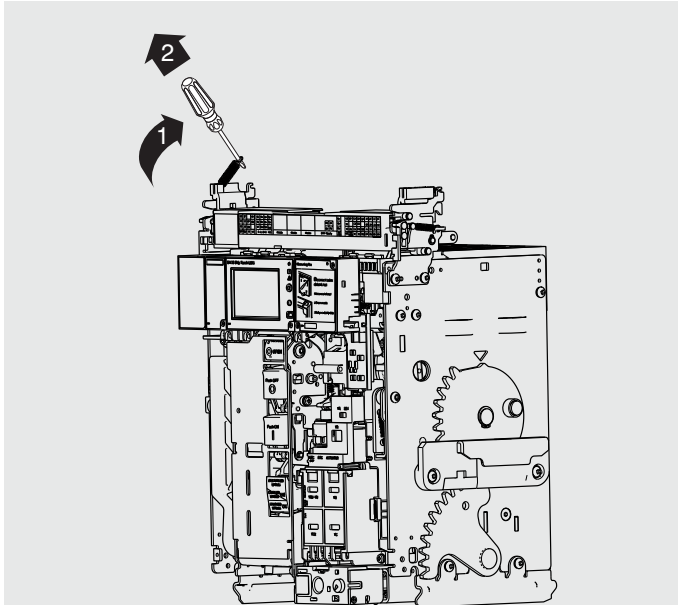

48

E2.2-E4.2-E6.2 W

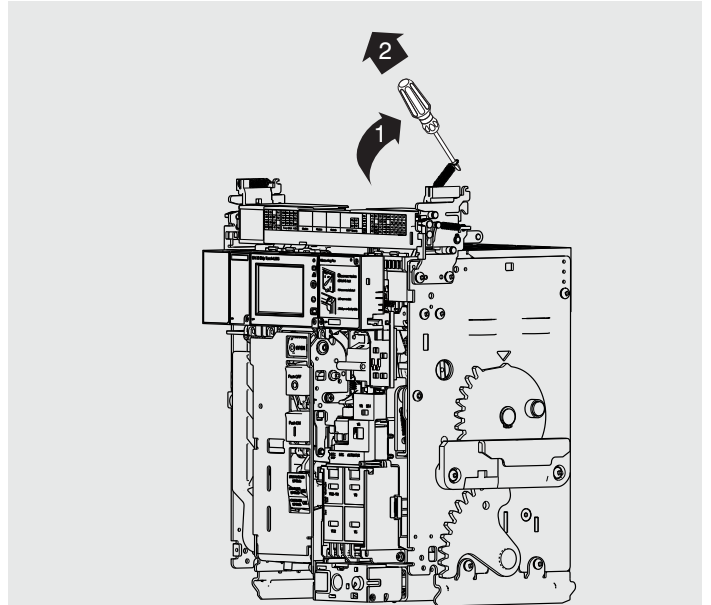

49

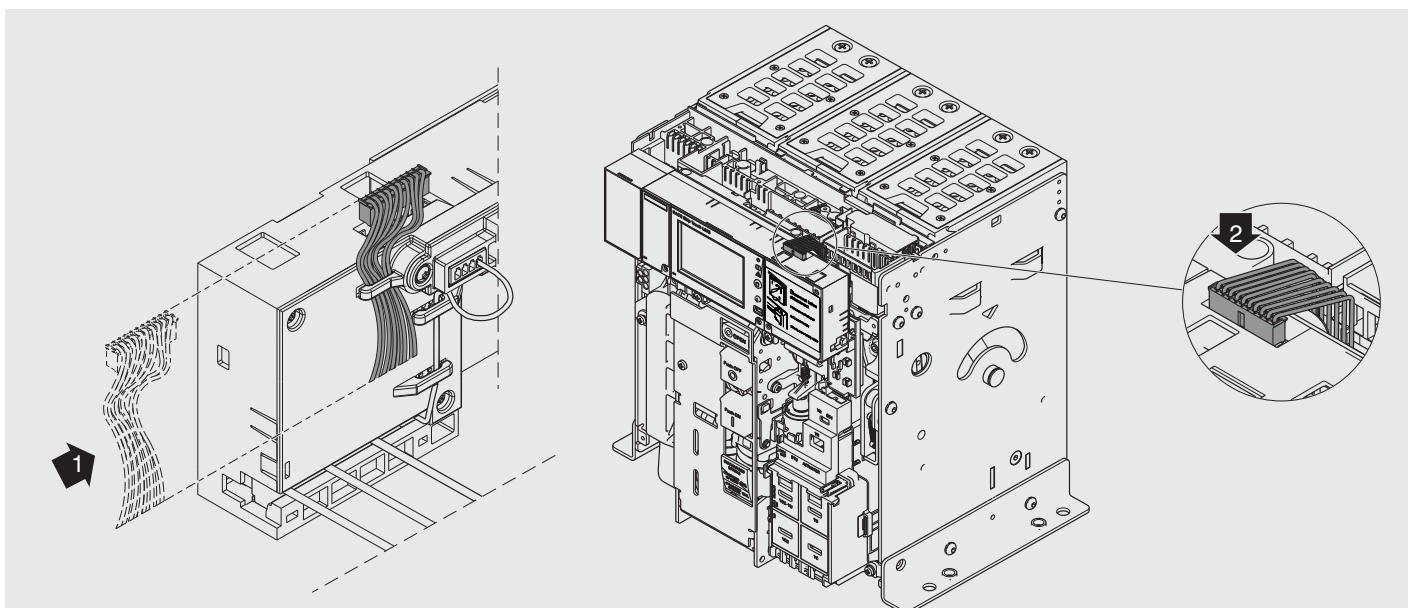

50

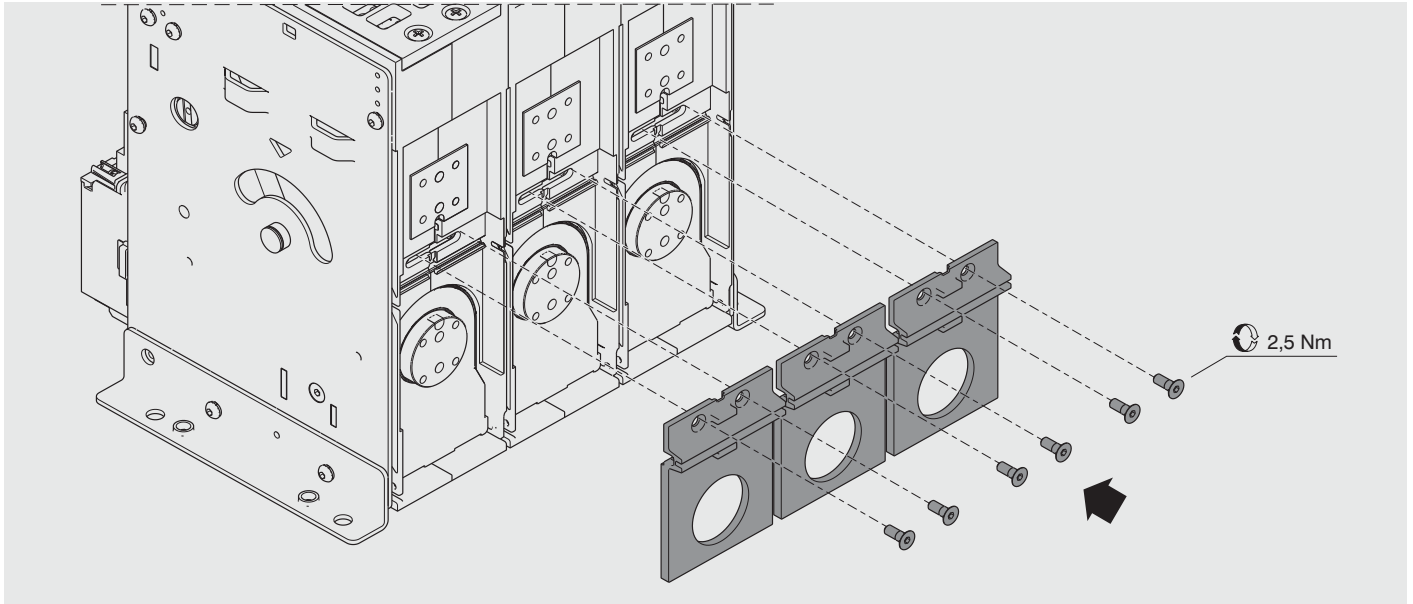

51

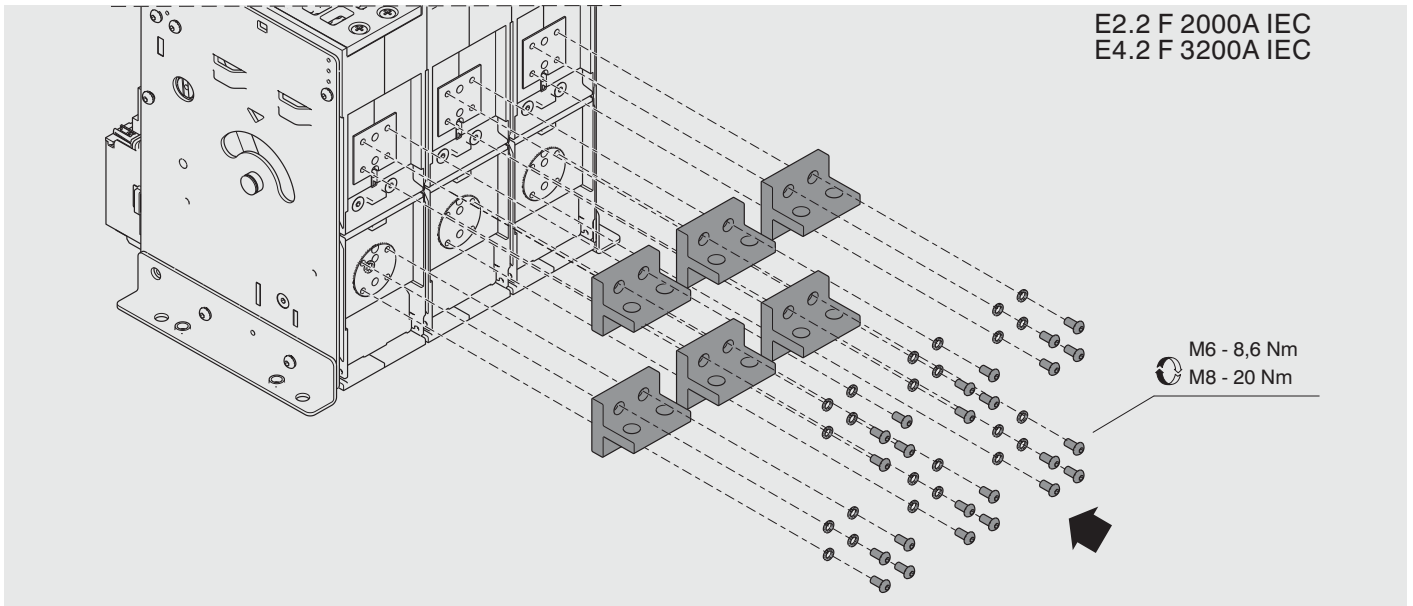

52

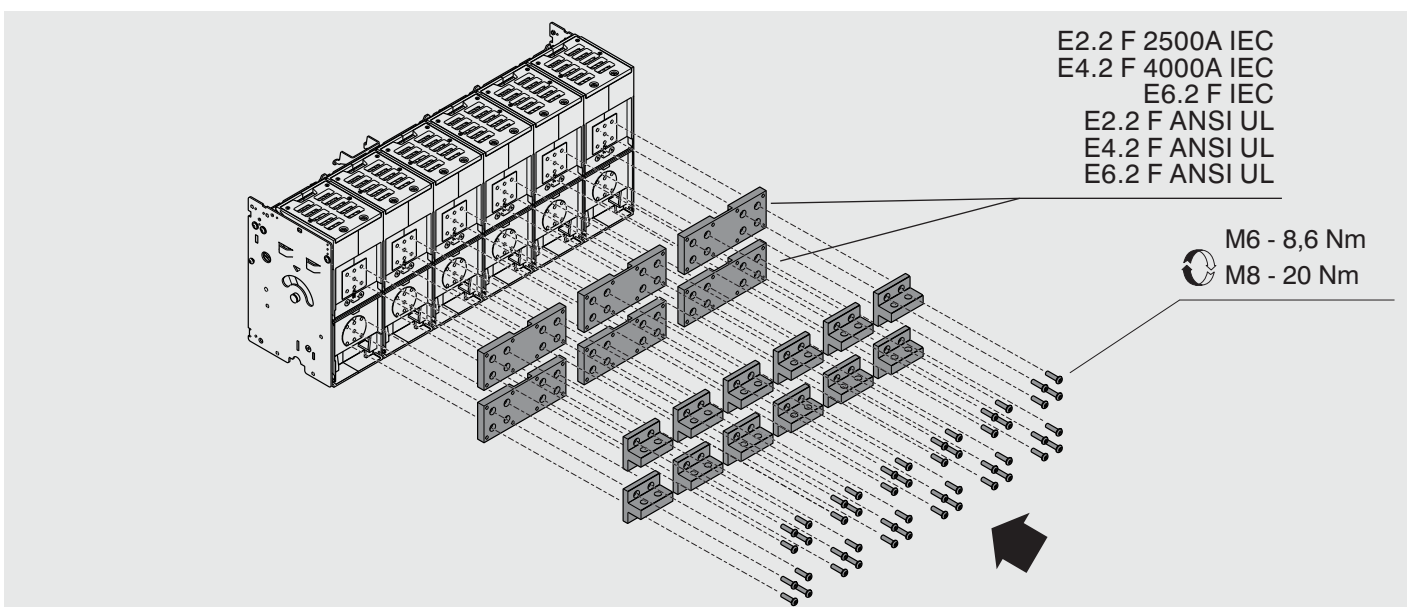

53

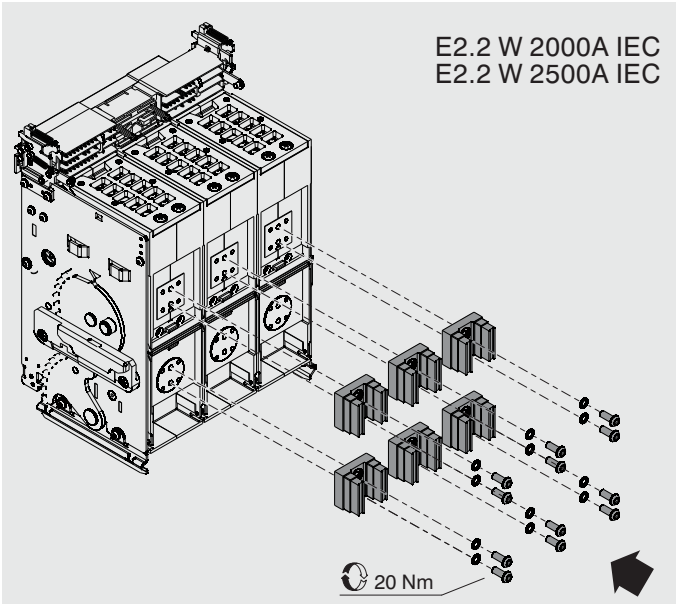

54

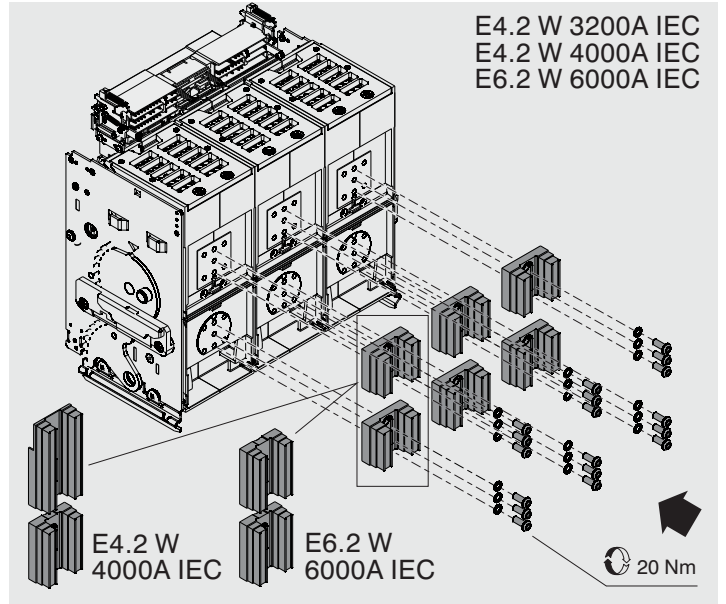

55

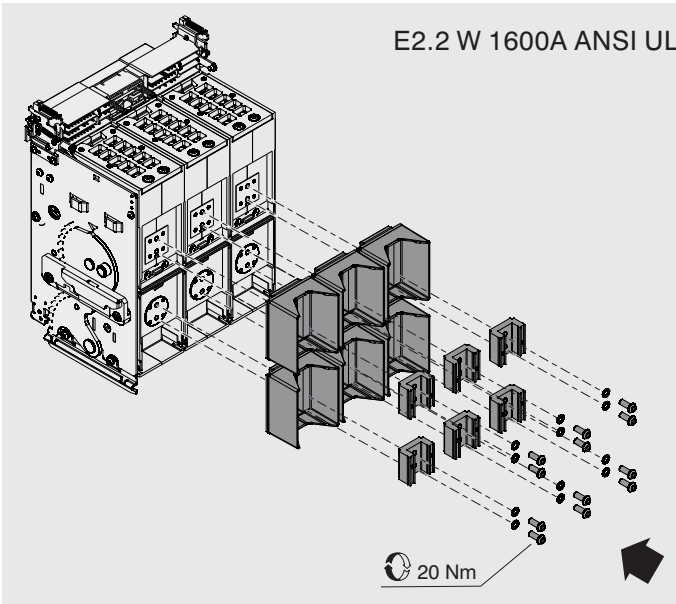

56

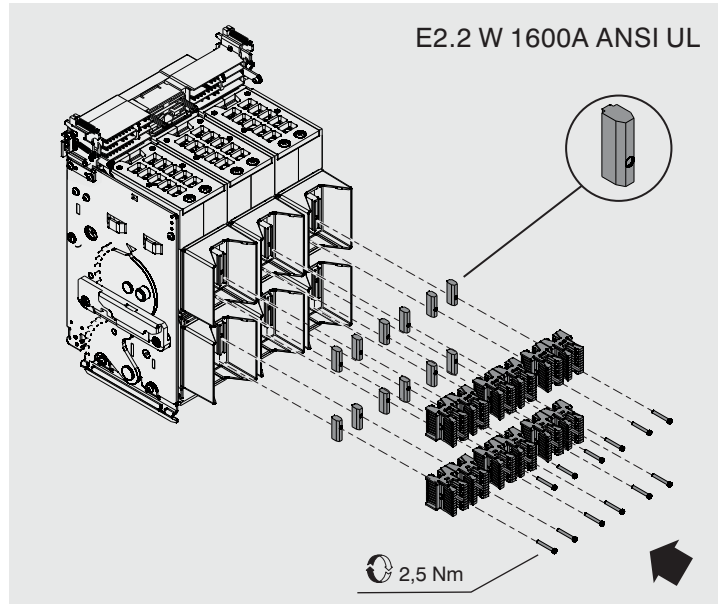

57

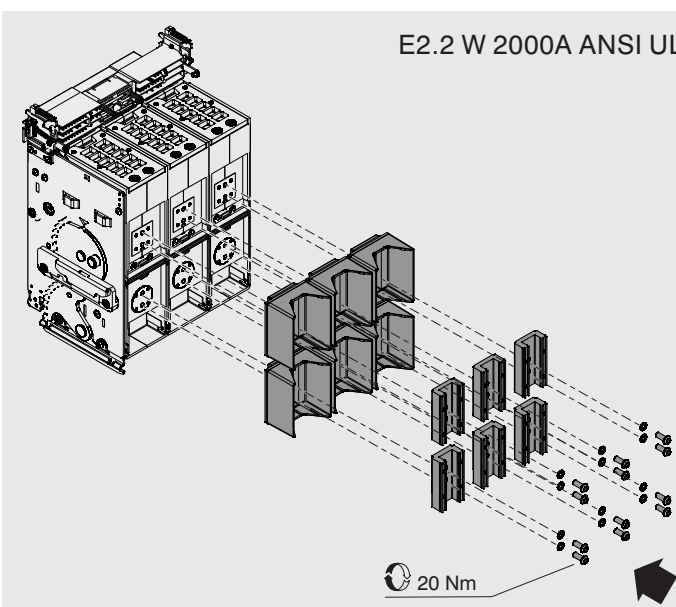

58

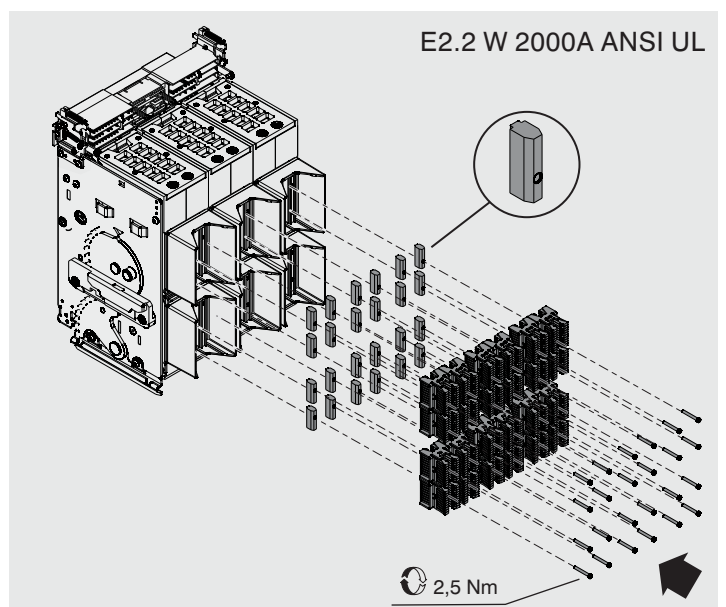

59

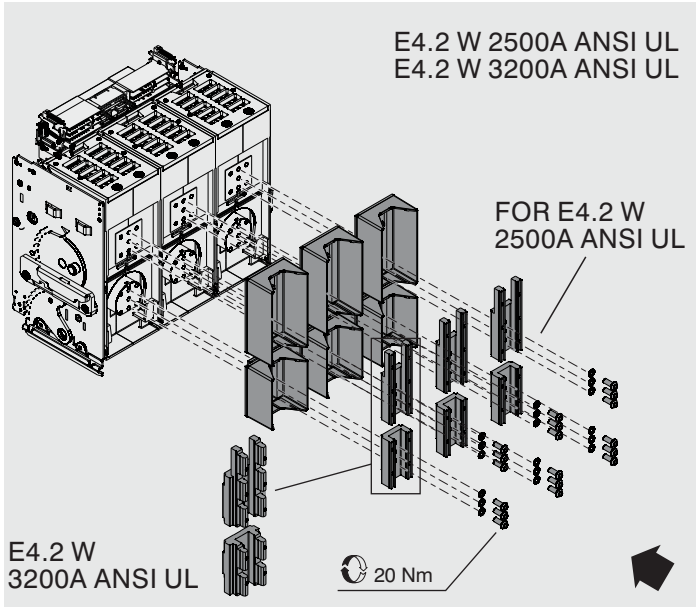

60

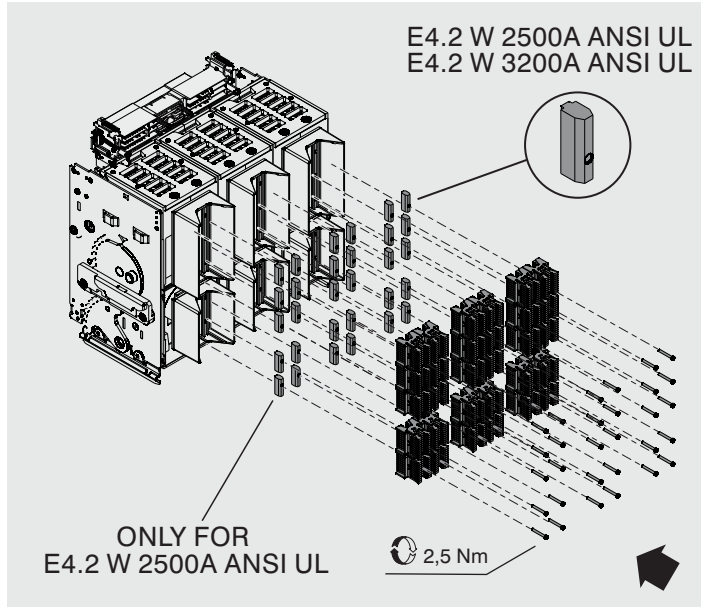

61

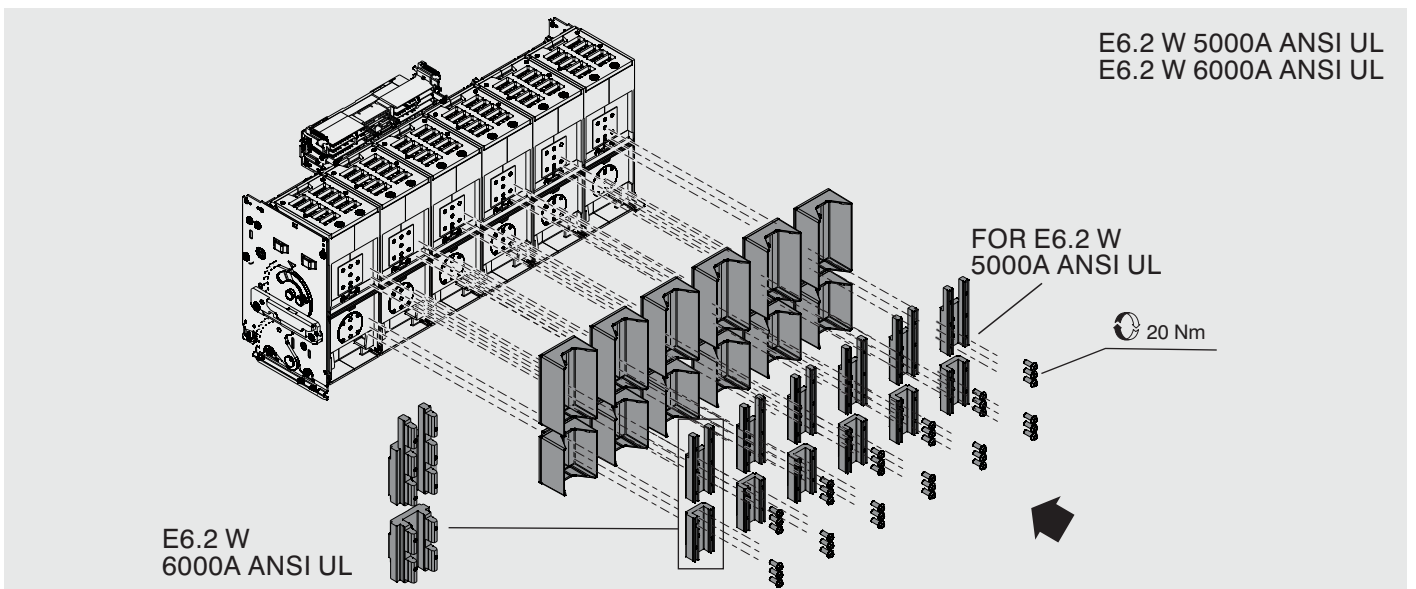

62

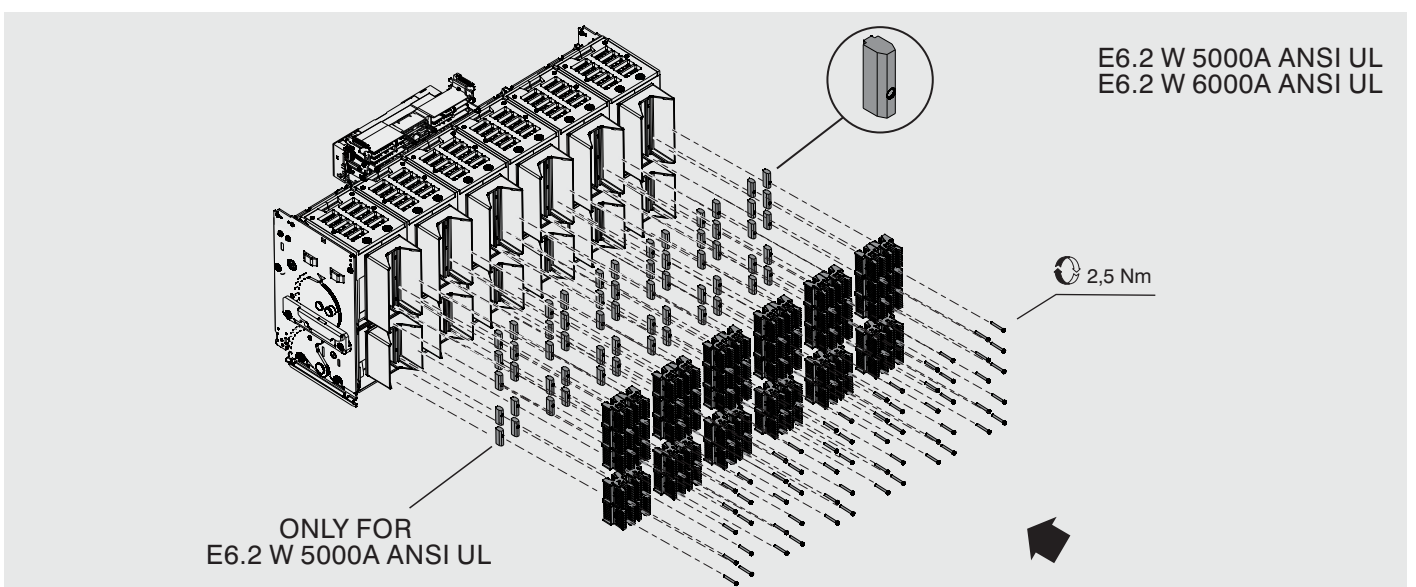

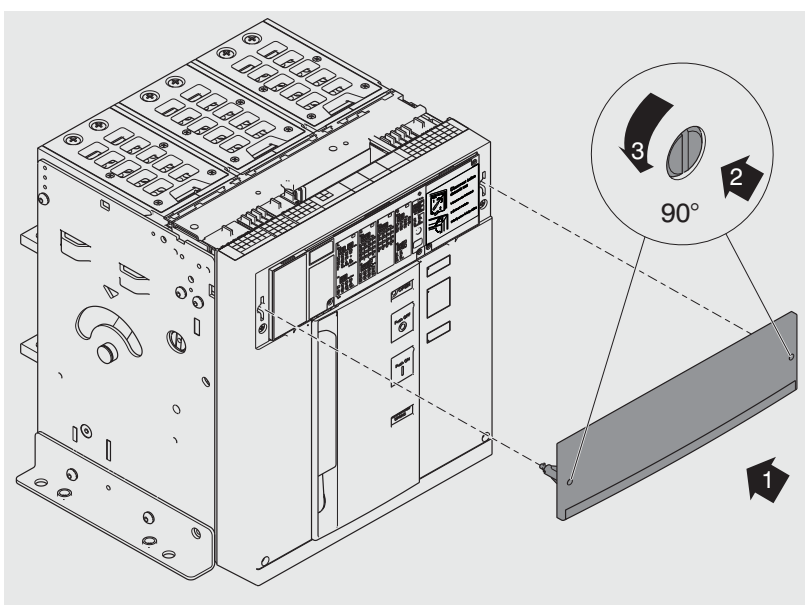
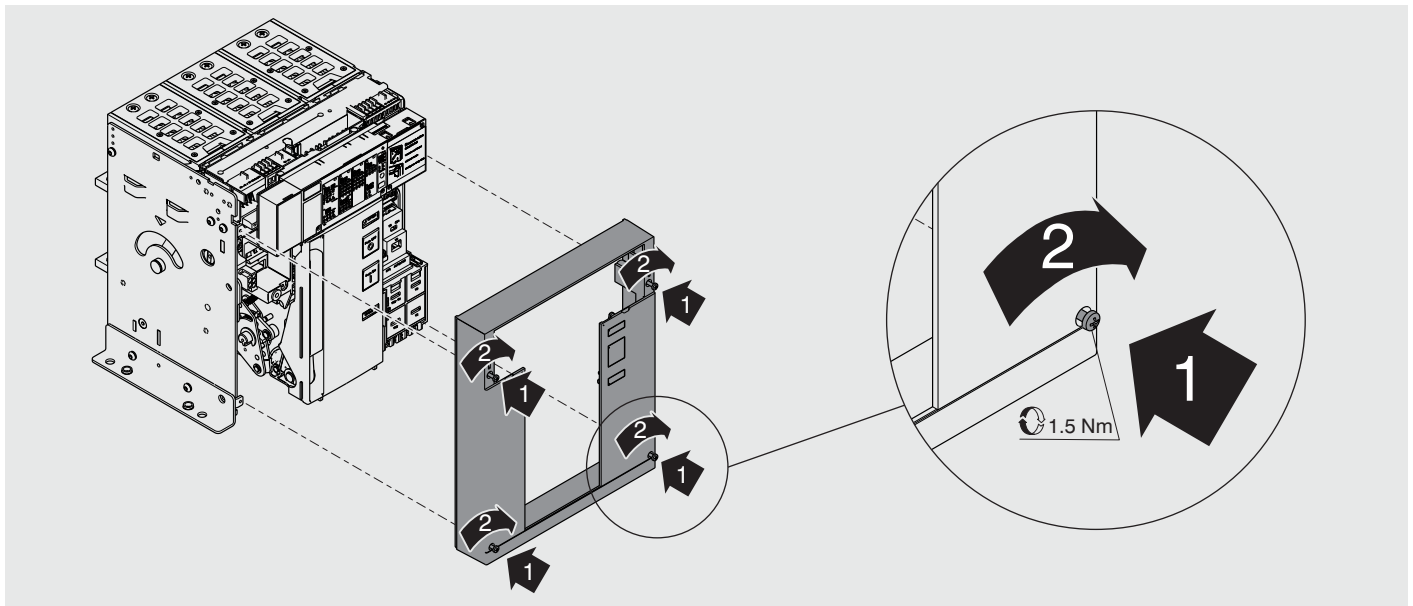
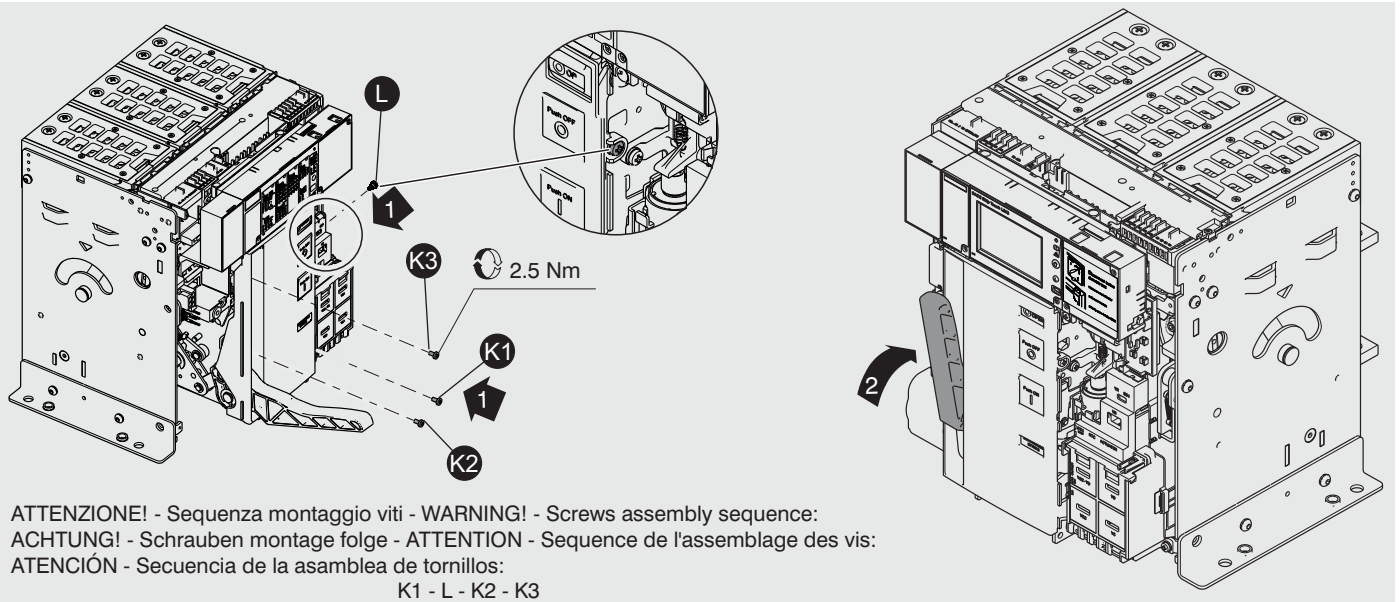

Inserire i contatti nella parte fissa come indicato nel documento [1SDH001000R0615](#)

Insert the contacts into the fixed part as shown in the document [1SDH001000R0615](#)

Einsetzen der Kontakte in den festen Teil wie in dokument [1SDH001000R0615](#) angegeben

Insérez les contacts dans la partie fixe comme indiqué dans le document [1SDH001000R0615](#)

Inserte los contactos en la parte fija como se muestra en el documento [1SDH001000R0615](#)

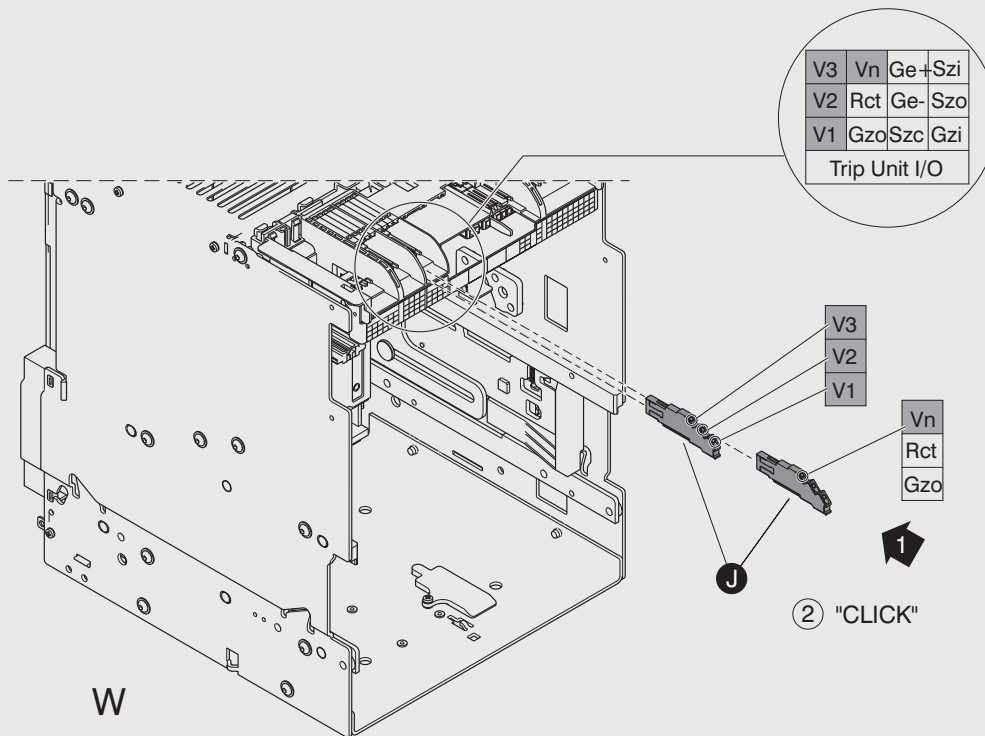
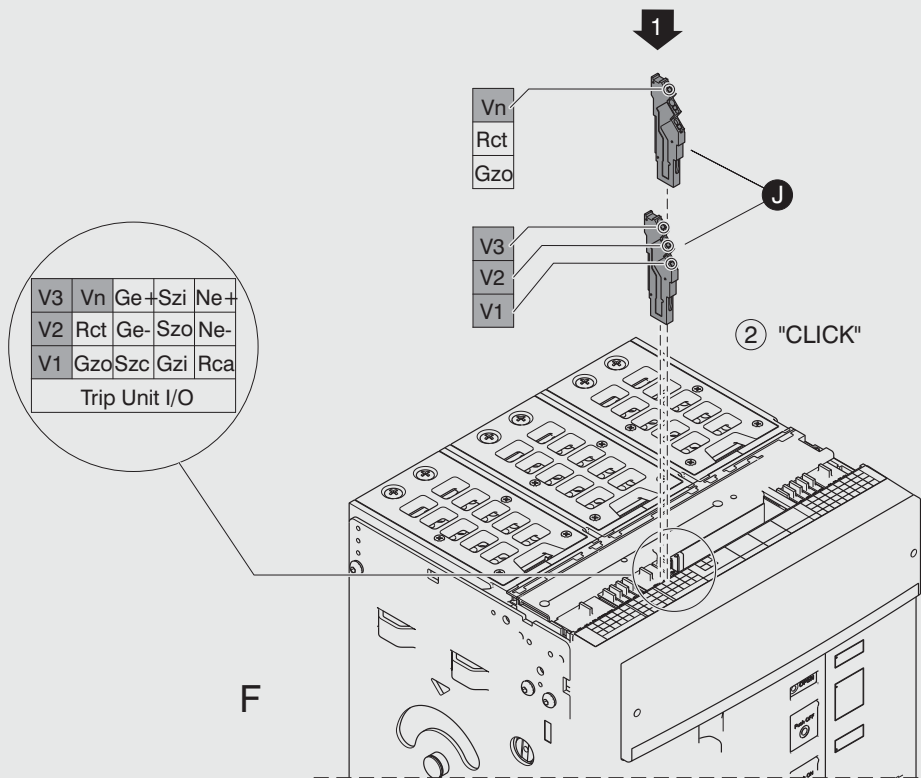

Procedura di installazione standard modulo Measurement Enabler
 Installation procedure for the standard Measurement Enabler module
 Standardinstallationsverfahren Modul Measurement Enabler
 Procédure d'installation standard module Measurement Enabler
 Procedimiento de instalación estándar módulo Measurement Enabler

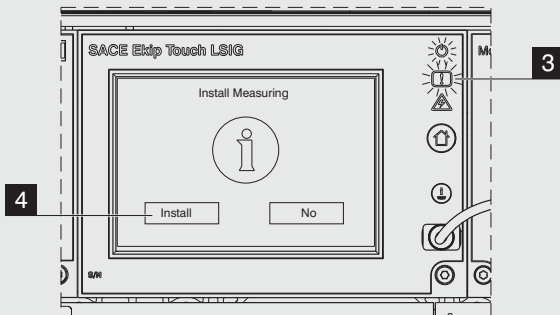
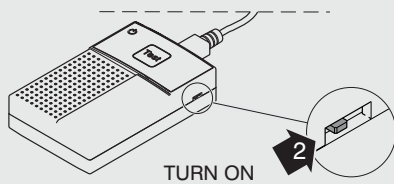
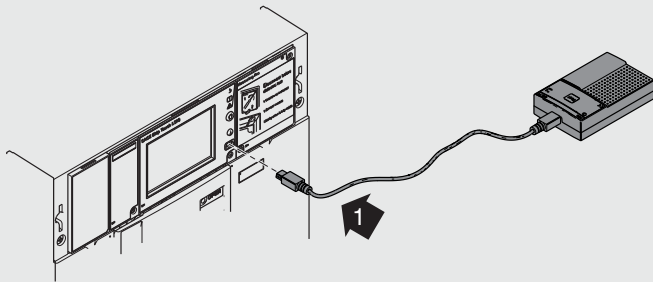

- Inserire Ekip TT E2.2 (1)
- Accendere Ekip TT E2.2 (2)
- Attendere 10 secondi
- Spia WARNING lampeggiante (3)
- Premere il tasto INSTALL (4) sul display dell'Ekip Touch
- Verificare assenza icone di allarme
- In caso di presenza icone di allarme consultare manuale

- Insert Ekip TT E2.2 (1)
- Turn on Ekip TT E2.2 (2)
- Wait 10 seconds
- WARNING LED flashing (3)
- Press the INSTALL button (4) on the display of the Ekip Touch
- Make sure there are no alarm icons present
- In case of alarm icons consult manual

- Ekip TT E2.2 (1) einstecken.
- Ekip TT E2.2 (2) einschalten.
- 10 Sekunden abwarten
- Leuchtanzeige WARNING blinkt (3)
- Die Taste INSTALL (4) auf Display von Ekip Touch drücken
- Sicherstellen, dass keine Alarm-Symbole vorhanden sind
- Im Falle eines Alarms Symbole siehe Handbuch

- Brancher Ekip TT E2.2 (1)
- Allumer Ekip TT E2.2 (2)
- Attendre 10 secondes
- voyant WARNING clignotant (3)
- Appuyer sur la touche INSTALL (4) sur l'afficheur de l'Ekip Touch
- Vérifier l'absence d'icônes d'alarme
- En cas d'icônes d'alarme se reporter au manuel

- Introducir Ekip TT E2.2 (1)
- Encender Ekip TT E2.2 (2)
- Esperar 10 segundos
- led de ADVERTENCIA intermitente (3)
- Pulsar la tecla INSTALL (4) en la pantalla del Ekip Touch
- Verificar la ausencia de iconos de alarma
- En el caso de los iconos de alarma, consulte el manual

For more information please contact:

ABB S.p.A.
 Via Pescaria, 5
 24123 Bergamo - Italy