

SAFETY PRODUCTS

# Smile emergency stop with indication

## Product manual





## Read and understand this document

Please read and understand this document before using the products. Please contact ABB for any questions or comments.

### Suitability for use

ABB Electrification Sweden AB shall not be responsible for conformity with any standards, codes, or regulations that apply to the combination of products in the customer's application or use of the product. Third party certificates for the products are available at <https://new.abb.com/low-voltage/products/safety-products>. This information by itself is not sufficient for a complete determination of the suitability of the products in combination with the end product, machine, system, or other application or use.

The following are some examples of applications for which particular attention must be given. This is not intended to be an exhaustive list of all possible uses of the products, nor is it intended to imply that the uses listed may be suitable for the products:

- Outdoor use uses involving potential chemical contamination or electrical interference, or conditions or uses not described in this document.
- Nuclear energy control systems, combustion systems, railroad systems, aviation systems, medical equipment, amusement machines, vehicles, and installations subject to separate industry or government regulations.
- Systems, machines, and equipment that could present a risk to life or property.

Please know and observe all prohibitions of use applicable to the products.

**NEVER USE THE PRODUCTS FOR AN APPLICATION INVOLVING SERIOUS RISK TO LIFE OR PROPERTY WITHOUT ENSURING THAT THE SYSTEM AS A WHOLE HAS BEEN DESIGNED TO ADDRESS THE RISKS, AND THAT THE ABB PRODUCT IS PROPERLY RATED AND INSTALLED FOR THE INTENDED USE WITHIN THE OVERALL EQUIPMENT OR SYSTEM.**

Descriptions and examples show how the product works and can be used. It does not mean that it fulfills the requirements for all types of machines and processes. The buyer/user is responsible for installing and using the product according to applicable standards and regulations. We reserve the right to make changes to the product and the documentation without prior notice.

# Table of Contents

<b>1</b>	<b>Introduction</b>	<b>4</b>
	Scope	4
	Audience	4
	Prerequisites	4
	Special notes	4
<b>2</b>	<b>Overview</b>	<b>5</b>
	General description	5
	Safety regulations	5
<b>3</b>	<b>Connections</b>	<b>6</b>
	Connections	7
<b>4</b>	<b>Installation and maintenance</b>	<b>10</b>
	Installation precautions	10
	Maintenance	10
<b>5</b>	<b>Operation</b>	<b>11</b>
	LED indication	11
<b>6</b>	<b>Model overview</b>	<b>12</b>
	Accessories	12
<b>7</b>	<b>Technical data</b>	<b>13</b>
	Dimensions	14
<b>8</b>	<b>Declarations of conformity</b>	<b>15</b>

# 1 Introduction

## Scope

The purpose of these instructions is to describe the emergency stop Smile and to provide the necessary information required for installation and operation.

## Audience

This document is intended for authorized personnel.

## Prerequisites

It is assumed that the reader of this document has knowledge of the following:

- Basic knowledge of ABB safety products.
- Knowledge of machine safety.

## Special notes

Pay attention to the following special notes in the document:

-  **Warning!** Danger of severe personal injury!  
An instruction or procedure which, if not carried out correctly, may result in injury to the technician or other personnel.
- Caution!** Danger of damage to the equipment!  
An instruction or procedure which, if not carried out correctly, may damage the equipment.
- NB:** Notes are used to provide important or explanatory information.

## 2 Overview

### General description

In order to fulfil the need for a small and easy to install E-stop, Smile has been developed. The size of the device makes it possible to be installed wherever needed. With M12 connections or cable and centralized mounting holes. Smile is very easy to install, especially on aluminium extrusions. There are different versions available, either with one or two M12 connections or cable. Two M12 connectors are used to enable the connection of E-stops in series. On the top of the Smile E-stop unit, an LED indicates the status.

 **Warning!** The emergency stop Smile normally needs to be complemented with other safety functions such as interlocking guards etc. Refer to risk analysis.

NB: The emergency stop shall **not** be used as normal stop of the machine, only in case of emergency.

### Safety regulations

 **Warning!**

Carefully read through this entire manual before using the device.

The devices shall be installed by a trained electrician following the Safety regulations, standards and the Machine directive.

Failure to comply with instructions, operation that is not in accordance with the use prescribed in these instructions, improper installation or handling of the device can affect the safety of people and the plant.

For installation and prescribed use of the product, the special notes in the instructions must be carefully observed and the technical standards relevant to the application must be considered.

In case of failure to comply with the instructions or standards, especially when tampering with and/or modifying the product, any liability is excluded.

### 3 Connections

#### Electrical connections - Smile

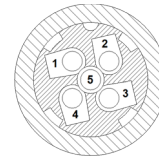
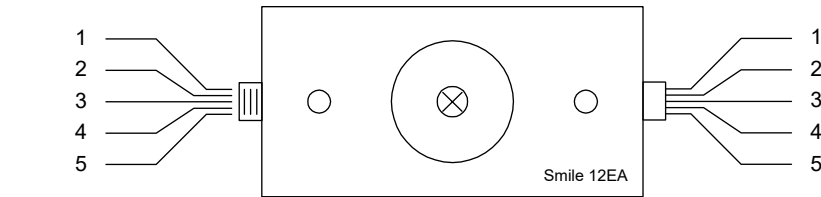
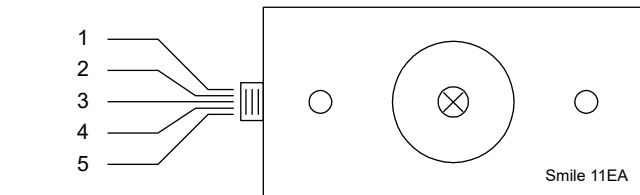
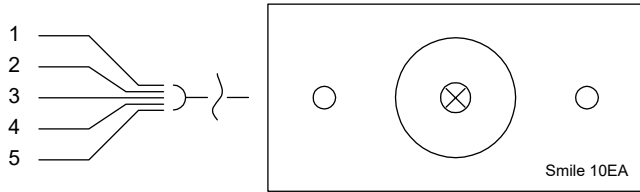
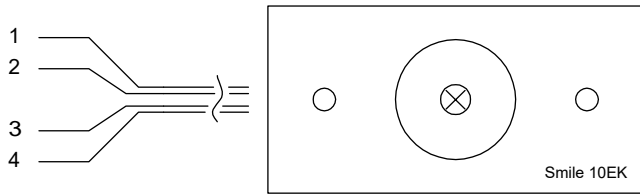

M12 5-pole male  
seen from cable  
side

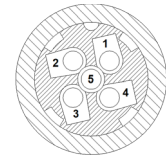

M12 5-pole female  
seen from cable  
side

#### Smile 12EA

##### Input

M12 5-pole male

- 1 ) Input 1
- 2 ) Input 2
- 3 ) 0 VDC<sup>1</sup>
- 4 ) Output 2, feedback
- 5 ) Output 1, feedback

##### Output

M12 5-pole female

- 1 ) Output 1
- 2 ) Output 2
- 3 ) 0 VDC
- 4 ) Input 2, feedback
- 5 ) Input 1, feedback

#### Smile 10EA

5-pole wired

- 1 ) Brown: Input 1
- 2 ) White: Input 2
- 3 ) Blue: 0 VDC<sup>1</sup>
- 4 ) Black: Output 2
- 5 ) Grey: Output 1

#### Smile 10EK

4x wires

- 1 ) Input 1
- 2 ) Input 2
- 3 ) Output 2
- 4 ) Output 1

#### Smile 11EA

M12 5-pole male

- 1 ) Input 1
- 2 ) Input 2
- 3 ) 0 VDC<sup>1</sup>
- 4 ) Output 2
- 5 ) Output 1

1. To be connected only if LED indication is required.

NB: Smile 10EA/11EA/12EA can be used with any safety PLC or safety relay, but if LED indication is required the voltage over pin-1 (+) and pin-3 (-) must be between 19.2 – 28.8 VDC.

## Connections

### Connections – Smile 10EA

Smile 10EA can be connected to either a safety PLC or a safety relay. The connection cable exits from underneath the unit.

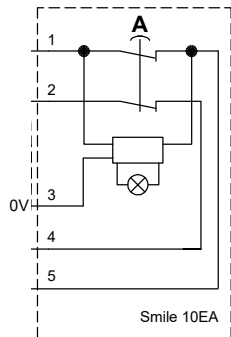

### Connections – Smile 11EA

Smile 11EA can be connected to either a safety PLC or a safety relay. Connection via M12 connector.

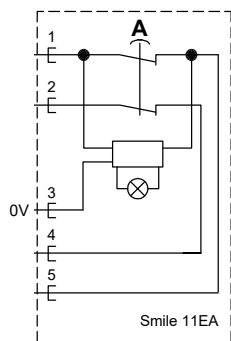

## Connections – Smile 12EA

Smile 12EA can be connected to either a safety PLC or a safety relay.

Connection via M12 connector + termination connector.

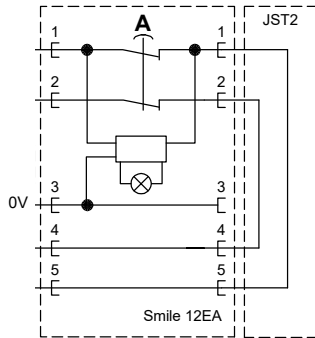

### Two channel serial connection example with LED indication.

Connection via M12 connector + termination connector. Note that there is no termination connector for the Smile 12EA (C), since this unit is being connected back to the safety PLC/safety relay via a separate cable.

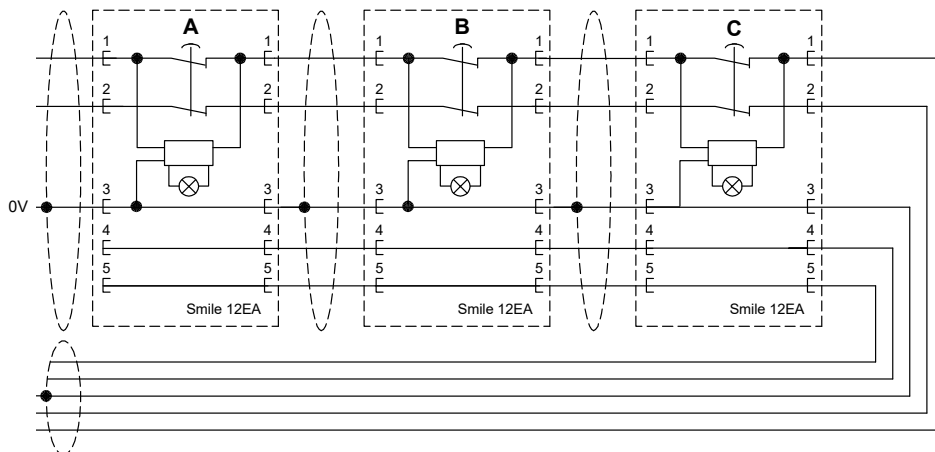

## Connection example – Smile 11EA & -12EA

Both Smile 11EA and -12EA can be connected to either a safety PLC or a safety relay.

### Two channel example with LED indication.

Connection via M12 connectors. Note that there is no termination connector as the Smile 11EA (C) completes the circuit without the need for a termination connector (JST2) or return cable.

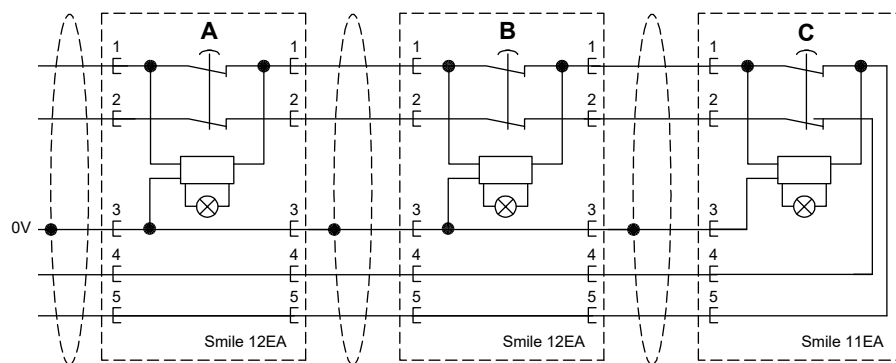

### LED indication example

The table shows the LED indication status of the emergency stop actuators from the connection example above.

Emergency stop actuator status				LED indication		
A	B	C		A	B	C
Released	Released	Released	<---	Green	Green	Green
Released	Released	Pressed	<---	Green	Green	Red
Released	Pressed	Released	<---	Green	Red	OFF
Released	Pressed	Pressed	<---	Green	Red	OFF
Pressed	Released	Released	<---	Red	OFF	OFF
Pressed	Released	Pressed	<---	Red	OFF	OFF
Pressed	Pressed	Released	<---	Red	OFF	OFF
Pressed	Pressed	Pressed	<---	Red	OFF	OFF

NB: More information about the LED indication can be found in chapter *Operation*.

## 4 Installation and maintenance

### Installation precautions

First mount Smile to the surface with two M5 bolts, and then attach the M12 connection(s).

 **Warning!** All the safety functions must be tested before starting up the system.

### Maintenance

 **Warning!**

The safety functions and the mechanics shall be tested regularly, at least once every year to confirm that all the safety functions are working properly (EN ISO 13849-1:2023, EN IEC 62061:2021).

In case of breakdown or damage to the product, contact ABB. Do not try to repair the product yourself since it may accidentally cause permanent damage to the product, impairing the safety of the device which in turn could lead to serious injury to personnel.

## 5 Operation

**⚠ Warning!** For a fault exclusion of the mechanical aspect of Smile consider IEC 60947-5-5, max 6 050 operations.

### LED indication

LED	Indication	Description
LED on button	Green	Safety device OK. Safety circuit closed.
	OFF	Safety circuit interrupted (when an emergency stop actuator is pressed down, all following units in the safety circuit lose the LED function).
	Red	Safety device actuator pressed down. Safety circuit interrupted.

## 6 Model overview

Type	Article number	Description
Smile 11EA	2TLA030051R0000	Emergency stop, red button, M12 5-pole male
Smile 11EAR	2TLA030051R0100	Emergency stop, red button, M12 5-pole male, reversed
Smile 12EA	2TLA030051R0200	Emergency stop, red button, M12 5-pole male, M12 5-pole female
Smile 10EA	2TLA030051R0400	Emergency stop, red button, 1 m cable (5-pole)
Smile 10EK	2TLA030051R0600	Emergency stop, red button, short leads (4x wires, no LED connection)
Smile 11SA	2TLA030051R0900	Safety stop, black button, M12 5-pole male

Smile 11EA

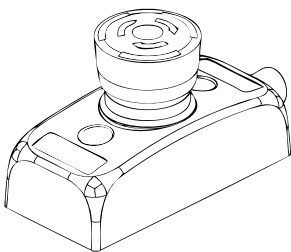

Smile 12EA

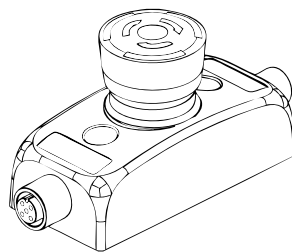

Smile 10EA

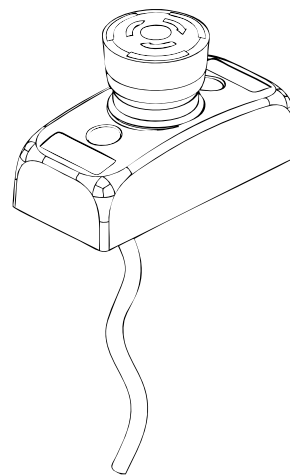

Smile 10EK

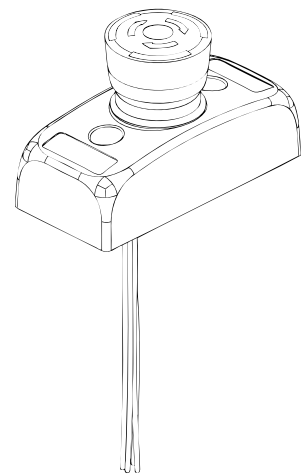

Smile 11EAR

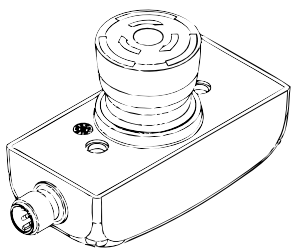

### Accessories

Type	Article number	Description
JST2	2TLA030051R1300	Termination for Smile 12
Emergency stop sign	2TLA030054R1000	Yellow surround with Ø32.5 mm hole. Without text. For Smile 11EAR. Adhesive film on back side.

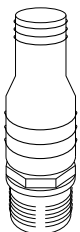

JST2  
Termination for Smile 12

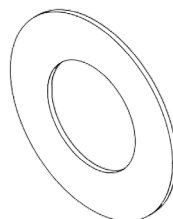

Emergency stop sign  
For reversed Smile

## 7 Technical data

Manufacturer	
Address	ABB Electrification Sweden AB SE-721 61 Västerås Sweden
Power supply	
Operating voltage (LED)	24 VDC ±10%
Current consumption (LED)	35 mA
Minimum current (switches)	10 mA 10 VDC/10 VAC
Maximum current (switches)	2 A 24 VDC
General	
Protection class	IP65
Ambient temperature	Storage: -30...+70°C Operation: -10...+55°C
Housing material	Polyamide PA66, Macromelt, polybutylenterephthalate PBT, Polypropene PP, UL 94 V0
Contact material	Silver alloy, gold plated
Connectors	Smile 10EA: 5-pole cable, 1 m Smile 10EK: 4x wires Smile 11x*: M12 5-pole male Smile 12x*: M12 5-pole male, M12 5-pole female * - x can be all models -EA, -EAR, -SA
Size	84 x 40 x 52 (L x W x H) – see drawing
Weight	~ 65 g
Colour	Yellow base, red or black button
Actuator force (E-stop button)	22 ± 4N
Actuator travel	~ 4 mm to latch
Mechanical life	> 50,000 operations
Impact resistance (half sinusoidal)	Max. 150 m/s <sup>2</sup> , pulse width 11 ms, 3-axis (as per EN IEC 60068-2-27)
Vibration resistance (half sinusoidal)	Max. 50m/s <sup>2</sup> at 10 Hz, 10 cycles, 3-axis (as per EN IEC 60068-2-6)
Climate resistance	
Damp heat, cyclical	96 hours, +25°C / 97%, +55°C / 93% relative humidity, as per EN IEC 60068-2-30
Damp heat, sustained	56 days, +40°C / 93% relative humidity, as per EN IEC 60068-2-78
Dry heat	96 hours, +70°C, as per EN IEC 60068-2-2
Cooling	96 hours, -40°C, as per EN IEC 60068-2-1
Salt mist	96 hours, +35°C in a chemical solution with NaCl as per EN IEC 60068-2-11

### Safety-related characteristic data and Conformity

Conformity	European Machinery Directive 2006/42/EC EN ISO 12100:2010, EN ISO 13849-1:2023, EN IEC 62061:2021, EN 60204-1:2018, IEC 60664-1:2007, EN 60947-5-5:1997+A1:2005+A11:2023+A2:2017, EN ISO 13850:2015
EN ISO 13849-1	Up to PL e, cat. 4 depending on system architecture
EN IEC 62061	Up to SIL3
Certificates	KIWA Inspecta AB
Safety data	
Mechanical reliability $B_{10D}$	$B_{10D} = 100\ 000$

NB: A safety function with an emergency stop Smile can achieve Cat. 4/PL e according to EN ISO 13849-1 only when a single Smile unit is connected to the control unit (safety-PLC or safety relay) in a dual channel configuration.

## Dimensions

### Dimensions – Smile

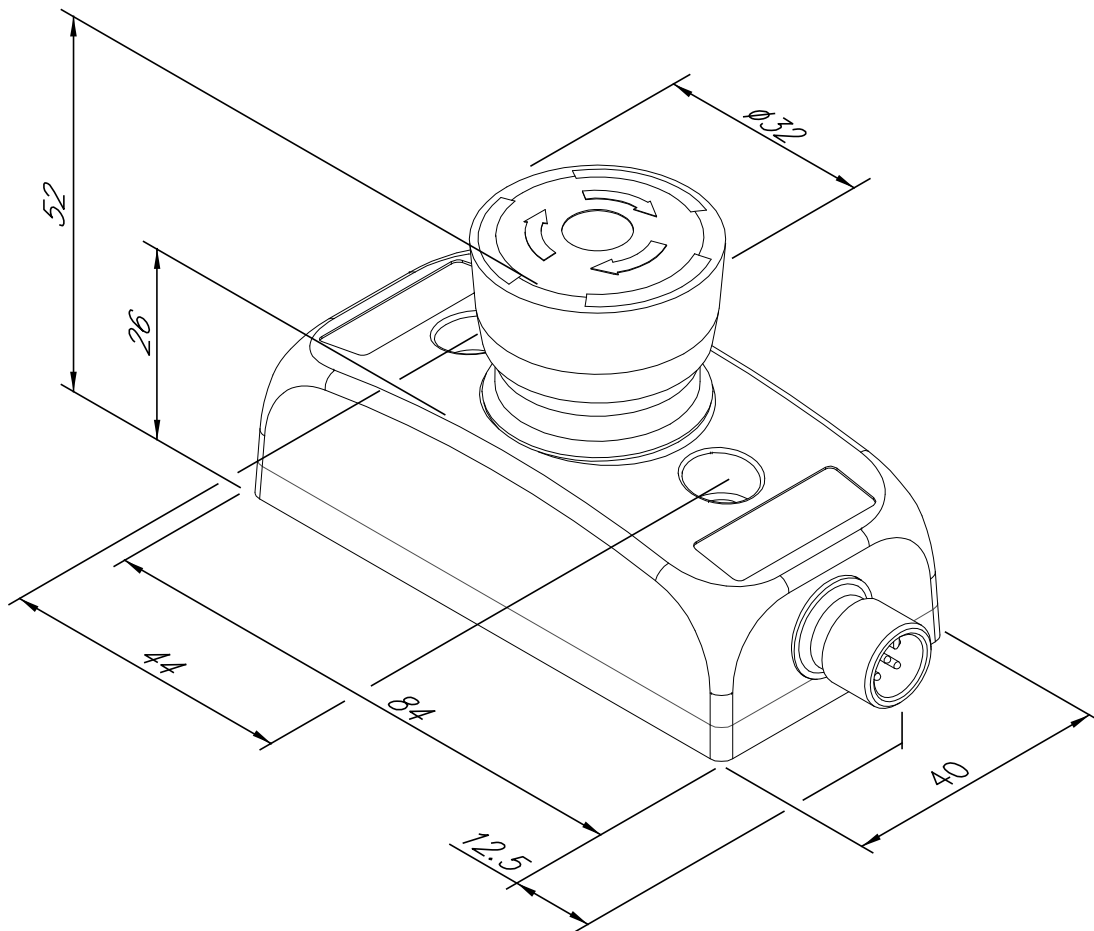

NB: All measurements in millimetres.

## 8 Declarations of conformity



### EC Declaration of conformity

(according to 2006/42/EC, Annex2A)

We	ABB Electrification Sweden AB SE-721 61 Västerås Sweden	declare that the safety components of ABB Electrification Sweden AB make with type designations and safety functions as listed below, is in conformity with the Directives
		2006/42/EC – Machinery 2011/65/EU – RoHS2 +2015/863
Authorised to compile the technical file	ABB Electrification Sweden AB SE-721 61 Västerås Sweden	
<b>Product</b>	<b>Certificate</b>	
Emergency stop devices Smile 10EA, 10EK, 11EA, 12EA, 11EAR, 41 INCA1	19-GBG-CM-0101	
Certification body	KIWA Inspecta AB Box 7178 SE-170 07 Solna Sweden	
Used harmonized standards	EN ISO 12100:2010, EN ISO 13849-1:2015, EN 60204-1:2018, EN ISO 13850:2015, EN 60947-5-5:1997+A1:2005+A11:2013+A2:2017	



Alessandro Pelandi  
R&D Manager  
Västerås 2024-05-03

---

[abb.com/lowvoltage](http://abb.com/lowvoltage)

Original



**EC Declaration of conformity**  
(according to 2006/42/EC, Annex2A)

We ABB Electrification Sweden AB  
SE-721 61 Västerås  
Sweden declare that the safety components of ABB Electrification  
Sweden AB make with type designations and safety  
functions as listed below, is in conformity with the Directives

2014/30/EU – EMC  
2011/65/EU – RoHS2 + 2015/863

**Product**

Stop button  
Smile 11 SA  
Smile 11 SA Tina  
INCA 1S  
INCA 1S Tina v2



Viktoria Sakar  
R&D team lead Electronics and Software  
Västerås 2022-11-09

---

[abb.com/lowvoltage](http://abb.com/lowvoltage)

Original



## Declaration of conformity

(according to 2008 No 1597)

We ABB Electrification Sweden AB  
SE-721 61 Västerås  
Sweden declare that the safety components of ABB Electrification Sweden AB  
make with type designations and safety functions as listed below, is  
in conformity with UK Statutory Instruments (and their amendments)

2008 No 1597 – Supply of Machinery (Safety) Regulations (MD)  
2012 No 3032 – Restriction of the Use of Certain Hazardous  
Substances in Electrical and Electronic Equipment Regulations  
(RoHS)

Authorized representative ABB Limited  
Tower Court  
Coventry  
CV6 5NX  
United Kingdom

Authorised to compile the technical file ABB Limited  
Tower Court  
Coventry  
CV6 5NX  
United Kingdom

### Products

Emergency stop devices  
INCA 1  
Smile versions 10EA, 10EK, 11EA,  
11EAR, 12EA

Used designated standards EN ISO 12100:2010, EN ISO 13849-1:2015, EN ISO 13850:2015  
EN 60204-1:2018, EN 60947-5-5:1997+A1:2005+A2:2017

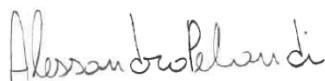

Alessandro Pelandi  
R&D Manager  
Västerås 2024-05-03

---

[abb.com/lowvoltage](http://abb.com/lowvoltage)

Original



## Declaration of conformity

We ABB Electrification Sweden AB SE-721 61 Västerås Sweden declare that the safety components of ABB Electrification Sweden AB make with type designations and safety functions as listed below, is in conformity with UK Statutory Instruments (and their amendments)

2016 No. 1091 – Electromagnetic Compatibility Regulations (EMC)  
2012 No 3032 – Restriction of the Use of Certain Hazardous Substances in Electrical and Electronic Equipment Regulations (RoHS)

Authorized representative ABB Limited  
Tower Court  
Coventry  
CV6 5NX  
United Kingdom

Authorised to compile the technical file ABB Limited  
Tower Court  
Coventry  
CV6 5NX  
United Kingdom

### Product

Stop button  
Smile 11SA  
Smile 11SA Tina  
INCA 1S  
INCA 1S Tina v2



Alessandro Pelandi  
R&D Manager  
Västerås 2023-09-11

---

[abb.com/lowvoltage](http://abb.com/lowvoltage)

Original