

PROTECTION AND CONNECTION

Spare parts for motorized change-over switches



Service offering

Providing a service offering for our products guarantees that our customers will be able to minimize unwanted production stops, thus maximizing the uptime of their processes.

We can increase the value for our customers by providing a well-organized service offering and professionally trained service personnel.

Our service offering includes spare parts and spare parts kits, emergency support and component exchange.



Spare parts

To provide service in a fast and efficient way, availability of original spare parts is essential.

Having critical spare parts available can significantly reduce the down-time that is associated with maintenance and failure.

The correct use of spare parts is essential to guarantee the same ABB quality as the original product.

Original spare parts are tested based on original production standards.

A 100% compatibility of all spare parts used in switches is necessary to ensure optimum performance. This is only possible with original spare parts.

Spare parts can be ordered through Parts OnLine (www.abb.com/partsonline). Parts OnLine (POL) is a web-based system that has the following features:

- Product information
- Stock quantities
- Order and delivery status
- Prices

Registration is necessary for some of these features.



Spare parts

OTM160...800_C_

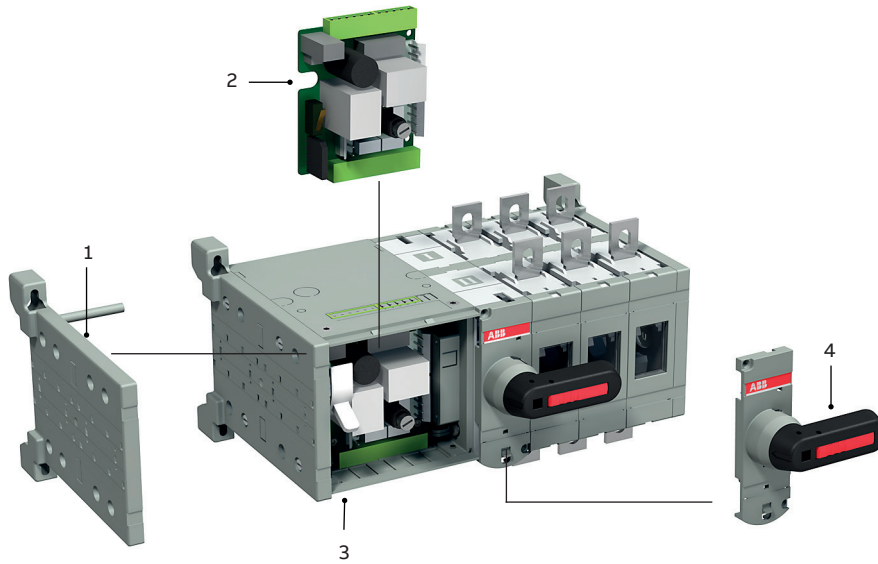

1. End plate | 2. Printed circuit board (PCB) | 3. Manual/motor selector switch | 4. Direct mounted handle

OTM1000...2500_C_

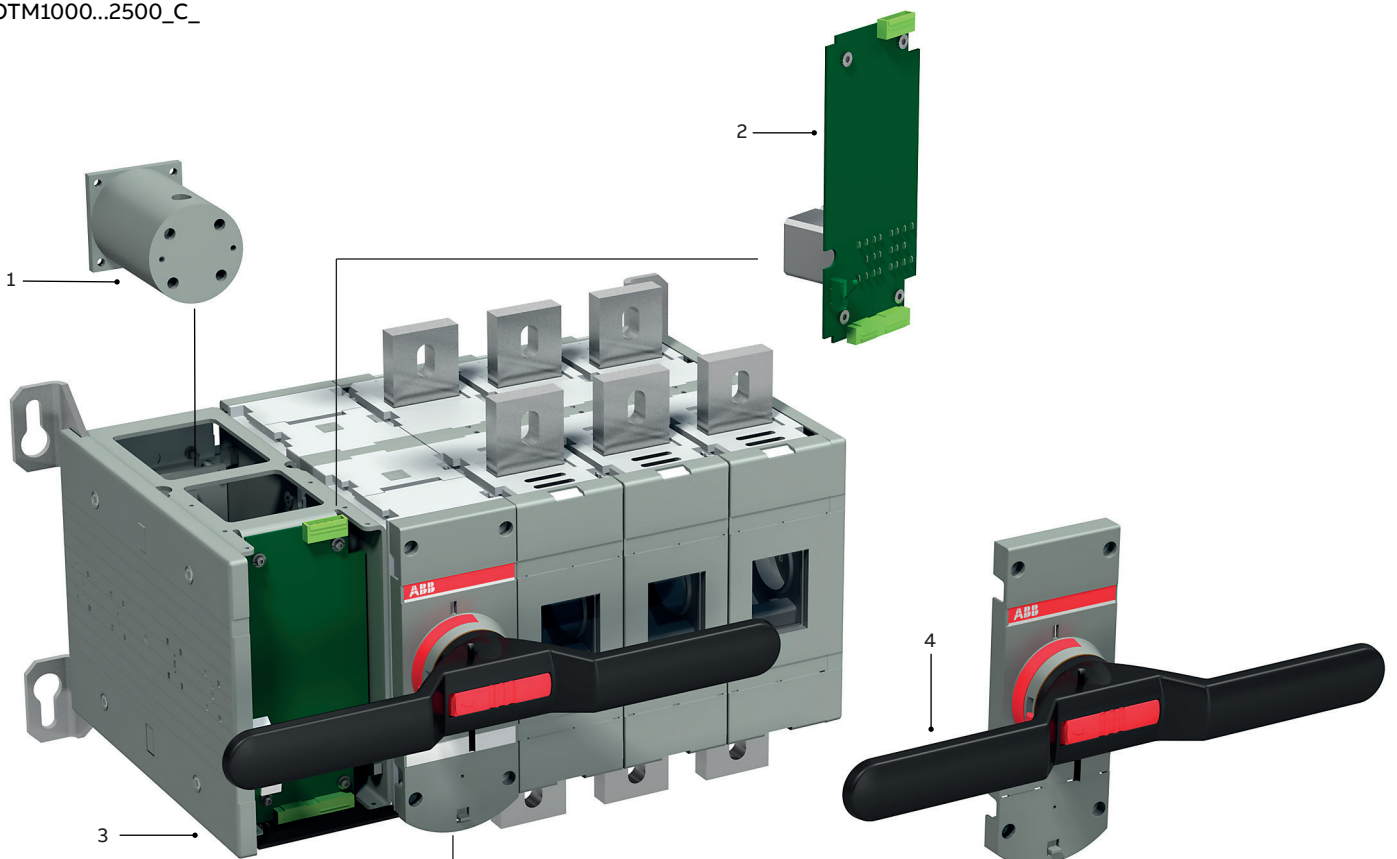

1. Motor | 2. Printed circuit board (PCB) | 3. Manual/motor selector switch | 4. Direct mounted handle

Ordering information

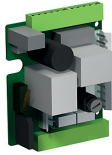

OME1...3PB

Printed Circuit Board (PCB)

Suitable for switches	Type	Order number	Units/type	Weight
			[pcs]	[kg]
OTM160...250E_CM230C	OME1PB-250	1SCA113420R1001	1	0
OTM315...400E_CM230C	OME2PB-250	1SCA113421R1001	1	0
OTM630...800E_CM230C	OME3PB-250	1SCA113422R1001	1	0
OTM1000...2500E_CM230C	OME4PB-250	1SCA120152R1001	1	0
OTM160...250E_CM110V	OME1PB-250	1SCA113420R1001	1	0
OTM315...400E_CM110V	OME2PB-250	1SCA113421R1001	1	0
OTM630...800E_CM110V	OME3PB-250	1SCA113422R1001	1	0
OTM1000...2500E_CM110V	OME4PB-250	1SCA120152R1001	1	0



OME4PB

Motor

Suitable for switches	Type	Order number	Units/type	Weight
			[pcs]	[kg]
OTM1000..2500	OMEM4M/250VDC	1SCA121246R1001	1	1



OMEM

Manual/Motor selector switch

Suitable for switches	Type	Order number	Units/type	Weight
			[pcs]	[kg]
OTM160..2500	OTMXP3	1SCA124523R1001	1	0



OTMXP3

Direct mounted handle

Suitable for switches	Type	Order number	Units/type	Weight
			[pcs]	[kg]
OTM160..250_C	OTV250ECMK	1SCA022804R0570	1	0.10
OTM315..400_C	OTV400ECMK	1SCA022843R2900	1	0.28
OTM630..800_C	OTV800ECMK	1SCA022804R3410	1	0.32
OTM1000..2500_C	OTV1000ECMK	1SCA111301R1001	1	0.77



OTV

Side plate

Suitable for motorized switches	Type	Order number	Units/type	Weight
			[pcs]	[kg]
OTM160..250_C	OTMXP001	1SCA121366R1001	1	0
OTM315..400_C	OTMXP002	1SCA121368R1001	1	0



OTV

Suitable for manual switches	Type	Order number	Units/type	Weight
			[pcs]	[kg]
OT160..250_C	OTXP001	1SCA121365R1001	1	0
OT315..400_C	OTXP002	1SCA121367R1001	1	0

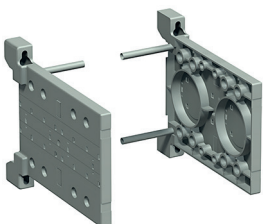

OT

ABB Oy
Protection and connection
P.O. Box 622
FI-65101 Vaasa, Finland
Phone: +358 10 22 11
Fax: +358 10 22 45708
E-Mail: firstname.surname@fi.abb.com
www.abb.com

