



EAN code
 PRI-41/110V: 8595188140508
 PRI-41/230V: 8595188140485
 PRI-41/400V: 8595188147446
 PRI-41/24V: 8595188140492
 PRI-42/110V: 8595188140539
 PRI-42/230V: 8595188140515
 PRI-42/400V: 8595188147484
 PRI-42/24V: 8595188140522

Technical parameters	PRI-41	PRI-42	
Supply circuit			
Supply terminals:	A1 - A2		
Voltage range:	AC 110 V, AC 230 V, AC 400 V or AC/DC 24 V (AC 50-60 Hz)		
Burden max.:	2.5 W/5 VA (AC 110 V, AC 230 V, AC 400 V), 1.4 W/2 VA (AC/DC 24 V)		
Max. dissipated power (Un + terminals):	5.5 W (110V, 230 V, 400 V) 4.5 W (24 V)		
Operating range:	-15 %; +10 %		
Measuring circuit			
Ranges*:	AC/DC 3.2 - 16 A (AC 50-60 Hz)	AC/DC 1 - 5 A (AC 50-60 Hz)	AC/DC 0.32 - 1.6 A (AC 50-60 Hz)
Terminals:	C - B1	C - B2	C - B3
Input resistance:	2.3 mΩ	11 mΩ	23 mΩ
Max. permanent current:	16 A	8 A	3 A
Inrush overload <1ms:	20 A	16 A	6 A
Time delay for I _{max} :	adjustable 0.1-10 s		
Time delay for I _{min} :	adjustable 0.1-10 s		
Accuracy			
Measuring accuracy:	5 %		
Repeat accuracy:	< 1 %		
Temperature dependency:	< 0.1 %/°C		
Limit values tolerance:	5 %		
Hysteresis (fault to OK):	selectable 5 %/10 % from range		
Output			
Number of contacts:	2x changeover/SPDT (AgNi/Silver Alloy)		
Current rating:	16 A/AC1		
Breaking capacity:	4000 VA/AC1, 384 W/DC		
Inrush current:	30 A/< 3 s		
Switching voltage:	250 V AC/24 V DC		
Output indication:	yellow LED		
Mechanical life:	10.000.000 ops.		
Electrical life (AC1):	100.000 ops.		
Other information			
Operating temperature:	-20 °C to 55 °C (-4 °F to 131 °F)		
Storage temperature:	-30 °C to 70 °C (-22 °F to 158 °F)		
Dielectrical strength:	4 kV (supply - output)		
Operating position:	any		
Mounting:	DIN rail EN 60715		
Protection degree:	IP40 from front panel/IP20 terminals		
Overvoltage category:	III.		
Pollution degree:	2		
Max. cable size (mm ²):	solid wire max. 1x 2.5 or 2x 1.5/ with sleeve max. 1x 1.5 (AWG 12)		
Dimensions:	90 x 52 x 65 mm (3.5" x 2" x 2.6")		
Weight:	248 g (8.7 oz.) (110 V, 230 V, 400 V); 145 g (5.1 oz.) (24 V)		
Standards:	EN 60255-1, EN 60255-26, EN 60255-27		

* Only one of the inputs can be connected.

- Used to monitor overloading/relief (machine, motor, etc.), check consumption, diagnostics on a remote device (burning, short circuit, increased current draw, etc.)
- Relay designed for monitoring DC and AC currents in three ranges.
- the relay controls the current size in two independent levels (I_{max}, I_{min}).
- Setting the monitored level I_{max} (in % of range).
- Setting the monitored level I_{min}. (in % of range - for PRI-42 - function WINDOW), (in % of the set upper limit - for PRI-41 - function HYSTERESIS).
- Function of second relay (independently/in parallel).
- Adjustable delay for eliminating short-term outages and surges for every level independently.
- Galvanically separated power supply from monitoring inputs.
- Output contact: for each current level.

Description

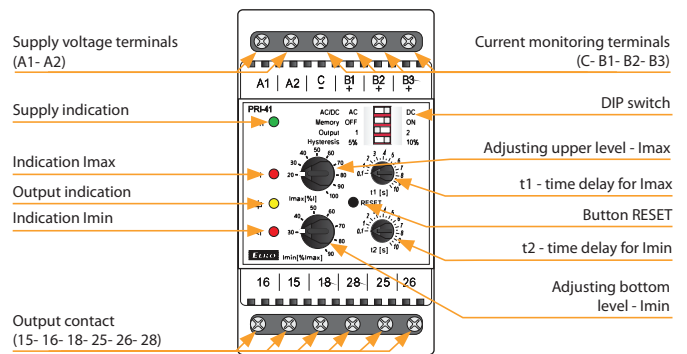

Description and importance of DIP switches

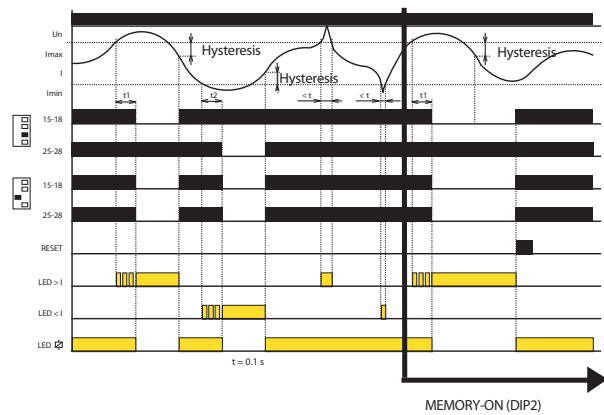
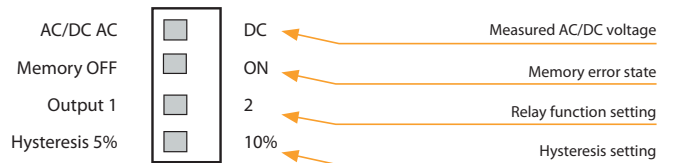

Connection

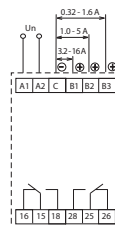

Symbol

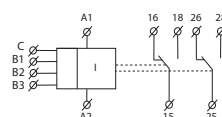

- If the value of the monitored current is in the zone between the set upper and lower levels, the status OK occurs - both relays are closed and the yellow LED illuminates. If the value of the monitored current is outside the set limits (> I_{max} or < I_{min}), an error state occurs.
- When moving to an error state I > I_{max}, it times the delay t₁ and a red LED > I simultaneously flashes. After the t₁ time elapses, the red LED > I illuminates and the relevant relay opens.
- When moving to an error state I < I_{min}, it times the delay t₂ and a red LED < I simultaneously flashes. After the time t₂ elapses, the red LED < I illuminates and the relevant relay opens.
- When moving from the error status to the OK status, the relevant red LED immediately goes out, and the corresponding relay closes.