

Karta katalogowa | Numer produktu: 2002-1402

4-przewodowa złączka przelotowa; 2,5 mm²; do zastosowań Ex e II; opis z boku i na środku; na szynę TS 35 x 15 i 35 x 7,5; Push-in CAGE CLAMP®; 2,50 mm²; pomarańczowa

www.wago.com/2002-1402

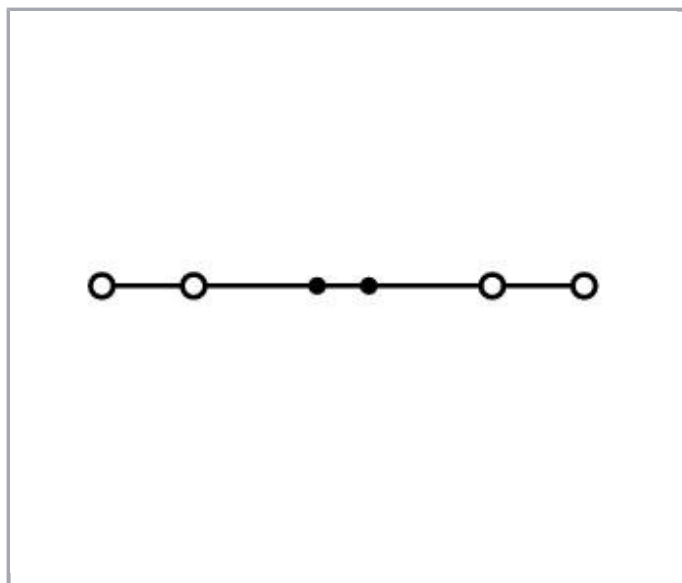
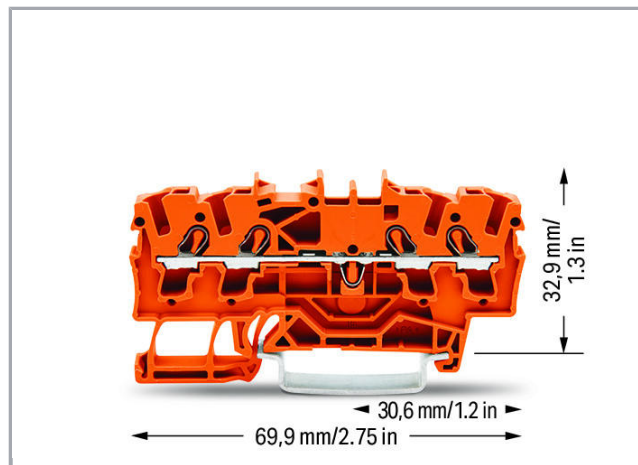
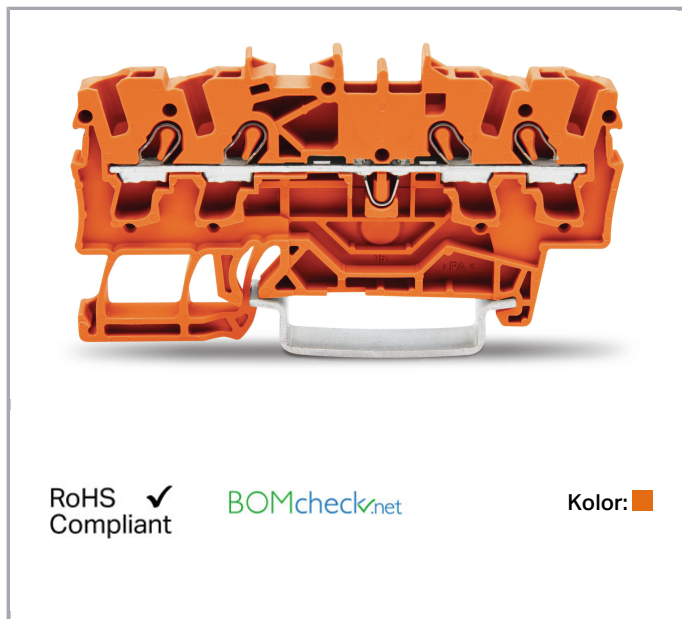

Data

Dane elektryczne

Zmiany zastrzeżone

WAGO ELWAG sp. z o. o.
ul. Piękna 58 a
50-506 Wrocław
Tel.: +48 71 3602972 | Fax: +48 71 3602999
Email: wago.elwag@wago.com

Masz pytania dotyczące naszych produktów?
Jesteśmy do Twojej dyspozycji pod numerem telefonu +48 71 360 29 70.

Parametry znamionowe zgodnie z IEC/EN 60664-1

napięcie znamionowe (III / 3)	800 V
napięcie znamionowe udarowe (III / 3)	8 kV
prąd znamionowy	24 A
prąd znamionowy 2	32 A
legenda parametrów znamionowych	(III / 3) ≙ kategoria przepięć III / stopień zanieczyszczenia 3

Parametry znamionowe zgodnie z UL 1059

napięcie znamionowe UL (Use Group B)	600 V
prąd znamionowy UL (Use Group B)	20 A
napięcie znamionowe UL (Use Group C)	600 V
prąd znamionowy UL (Use Group C)	20 A
parametry zgodnie z	UL 1059

Parametry znamionowe zgodnie z CSA

napięcie znamionowe CSA (Use Group B)	600 V
prąd znamionowy CSA (Use Group B)	20 A
napięcie znamionowe CSA (Use Group C)	600 V
prąd znamionowy CSA (Use Group C)	20 A

Approvals Ex

napięcie znamionowe EN (Ex e II)	550 V
prąd znamionowy (Ex e II)	22 A
prąd znamionowy (Ex e II) z mostkami	20 A

Parametry zacisku

technika podłączania przewodu	Push-in CAGE CLAMP®
rodzaj montażu	Push-in przyrząd montażowy
materiał podłączanego przewodu	miedź
przekrój znamionowy	2,5 mm ²
przewód jednodrutowy	0,25 ... 4 mm ² / 22 ... 12 AWG
przewód jednodrutowy, montaż wtykowy bez pomocy narzędzi	0,75 ... 4 mm ² / 18 ... 12 AWG
przewód linkowy	0,25 ... 4 mm ² / 22 ... 12 AWG
przewód linkowy z tulejką z kołnierzem z tworzywa	1 ... 2,5 mm ² / 18 ... 12 AWG
przewód linkowy z tulejką, montaż wtykowy bez pomocy narzędzi,	1 ... 2,5 mm ² / 18 ... 12 AWG

Zmiany zastrzeżone

WAGO ELWAG sp. z o. o.
 ul. Piękna 58 a
 50-506 Wrocław
 Tel.: +48 71 3602972 | Fax: +48 71 3602999
 Email: wago.elwag@wago.com

Masz pytania dotyczące naszych produktów?
 Jesteśmy do Twojej dyspozycji pod numerem telefonu +48 71 360 29 70.



min.	
dł. odizolowania przewodu	10 ... 12 mm / 0.39 ... 0.47 cal
łączna liczba zacisków	4
łączna liczba potencjałów	1
liczba poziomów	1
rodzaj oprzewodowania	oprzewodowanie od czoła
wskazówka dot. przekroju przewodu	Depending on the conductor characteristic, a conductor with a smaller cross section can also be inserted via push-in termination.
liczba miejsc na mostek	2

Wymiary

szerokość	5,2 mm / 0.205 inch
wysokość od górnej krawędzi szyny	32,9 mm / 1.295 inch
głębokość	69,9 mm / 2.752 inch

Dane mechaniczne

konstrukcja	konstrukcja pozioma
rodzaj montażu	szyna montażowa 35
plaszczyna opisu	opis na środku / z boku

Dane materiałowe

kolor	pomarańczowa
materiał izolacyjny	poliamid 66 (PA 66)
obciążenie ogniowe	0,122 MJ
masa	7,4 g

Dane handlowe

Grupa produktów	22 (TOPJOB S)
rodzaju opakowania	BOX
Kraj pochodzenia	DE
GTIN	4017332999298
Nr taryfy celnej	85369010000

Aprobaty / certyfikaty

Aprobaty Ex

Logo	Aprobata	Norma	Nazwa aprobaty
------	----------	-------	----------------



Zmiany zastrzeżone

WAGO ELWAG sp. z o. o.
ul. Piękna 58 a
50-506 Wrocław
Tel.: +48 71 3602972 | Fax: +48 71 3602999
Email: wago.elwag@wago.com



Masz pytania dotyczące naszych produktów?
Jesteśmy do Twojej dyspozycji pod numerem telefonu +48 71 360 29 70.

	AEx Underwriters Laboratories Inc.	UL 60079	20190704- E185892
	ATEX Physikalisch Technische Bundesanstalt (PTB)	EN 60079	PTB 03 ATEX 1162 U (II 2 G/D Ex e II bzw. I M 2 Ex e I)
	IECEX Physikalisch Technische Bundesanstalt	IEC 60079	IECEX PTB 03.0004U (Ex eb IIC Gb or Ex eb I Mb)

Regulacje krajowe

Logo	Aprobata	Norma	Nazwa aprobaty
	CCA DEKRA Certification B.V.	EN 60947	NTR NL 7730
	CSA DEKRA Certification B.V.	C22.2 No. 158	1536069
	KEMA/KEUR DEKRA Certification B.V.	EN 60947	71- 107687

Aprobaty Przemysł morski

Logo	Aprobata	Norma	Nazwa aprobaty
	ABS American Bureau of Shipping	EN 60947	20- HG1941090- PDA
	BV Bureau Veritas S.A.	EN 60947	38586/A0 BV
	DNV GL Det Norske Veritas, Germanischer Lloyd	-	TAE00001V2

Zmiany zastrzeżone

WAGO ELWAG sp. z o. o.
ul. Piękna 58 a
50-506 Wrocław
Tel.: +48 71 3602972 | Fax: +48 71 3602999
Email: wago.elwag@wago.com

Masz pytania dotyczące naszych produktów?
Jesteśmy do Twojej dyspozycji pod numerem telefonu +48 71 360 29 70.



LR
Lloyds Register

EN 60947

91/20112
(E9)

Aprobaty UL

Logo	Aprobata	Norma	Nazwa aprobaty
	cURus Underwriters Laboratories Inc.	UL 1059	E45172

Wskazówki dotyczące obsługi

Inserting a conductor

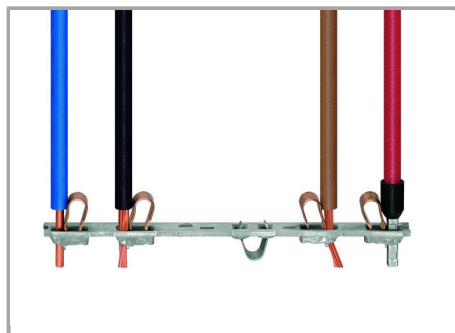

All conductor types at a glance

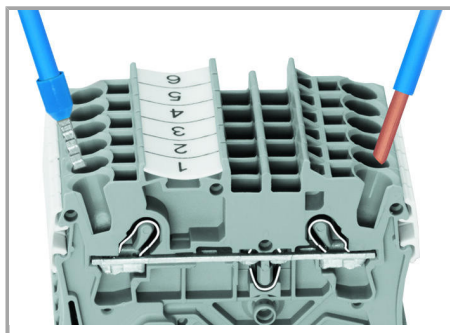

Terminating solid and ferruled conductors via push-in connection.

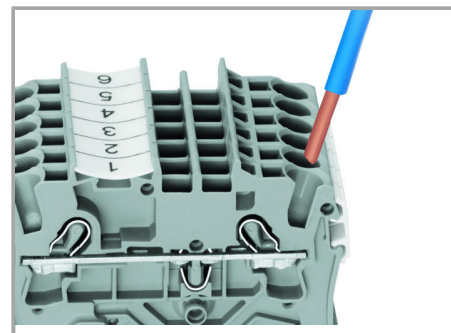

Inserting conductors via push-in termination.

Solid conductors with cross-sections from either one size above, or up to two sizes below, the rated cross-section can be simply pushed in – no tools needed.

Zmiany zastrzeżone

WAGO ELWAG sp. z o. o.
ul. Piękna 58 a
50-506 Wrocław
Tel.: +48 71 3602972 | Fax: +48 71 3602999
Email: wago.elwag@wago.com

Masz pytania dotyczące naszych produktów?
Jesteśmy do Twojej dyspozycji pod numerem telefonu +48 71 360 29 70.

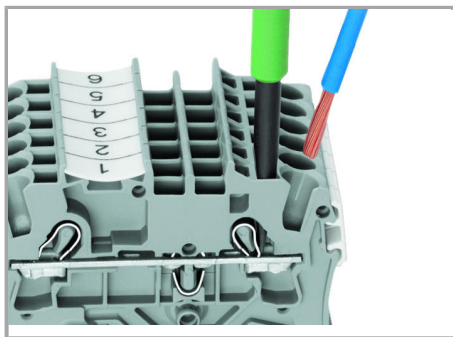

Inserting a conductor via operating tool.



Conductor termination – Insulation stop.

Connecting fine-stranded conductors without ferrules, or small cross-sectional conductors that cannot be pushed in, is performed similarly to the original CAGE CLAMP® – just use an operating tool.

The smart feature:

To open the clamp, the operating tool is inserted vertically. The conductor entry is less than 15 degrees for easier wiring.

Jumpered

Zmiany zastrzeżone

WAGO ELWAG sp. z o. o.
ul. Piękna 58 a
50-506 Wrocław
Tel.: +48 71 3602972 | Fax: +48 71 3602999
Email: wago.elwag@wago.com

Masz pytania dotyczące naszych produktów?
Jesteśmy do Twojej dyspozycji pod numerem telefonu +48 71 360 29 70.



The push-in type jumper bar system is based on the common plug and socket principle. Each terminal block is spring-loaded with a double socket and a resilient CrNi steel spring. The jumper contact material is pure electrolytic copper, which allows for an extremely small design capable of carrying the full-rated current of the terminal block. Ground terminal blocks can also be commoned using the same jumper system. Custom jumpers are created by breaking and removing jumper contacts (2000, 2001, 2002, 2004 Series).

Removing a push-in type jumper bar.

Insert the operating tool between the jumper and the partition wall of the dual jumper slots, then lift up the jumper.

Place the operating tool in the center of jumpers up to five contacts (see above), or alternately on both sides for jumpers with more than five contacts.

Jumpered

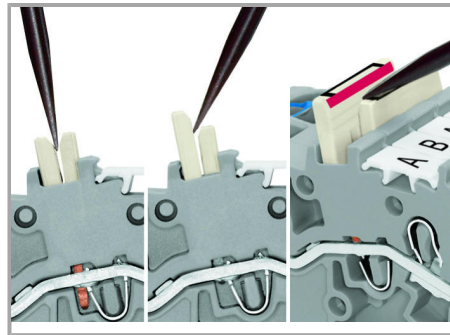
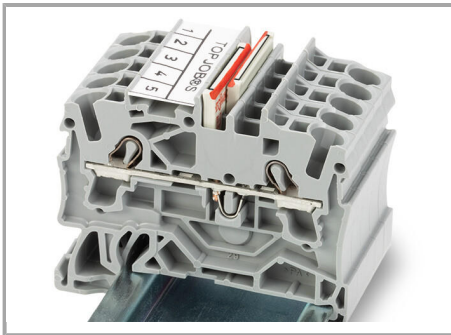

Locate red stripes of the staggered jumpers on the inside.

Removing a staggered jumper:

Insert staggered jumper and push down until it hits backstop.

Insert the operating tool between the staggered jumpers, then lift up the jumper.

Jumpered

Zmiany zastrzeżone

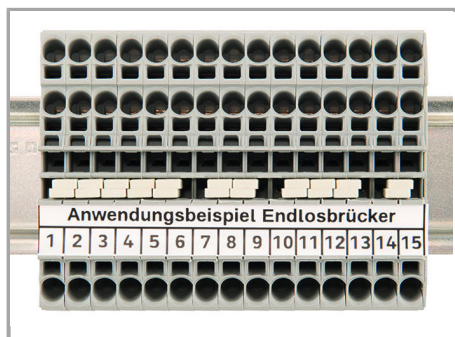

Continuous jumpers (2002 Series) readily connect an endless number of terminal blocks to each other via a single jumper slot. Use the second jumper slot for additional commoning or testing.

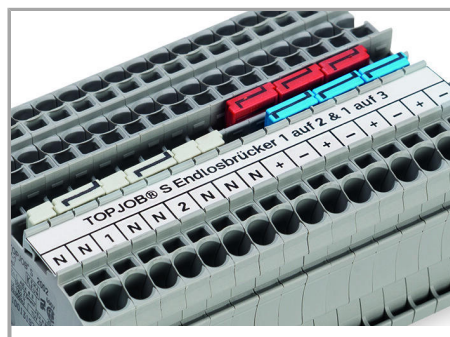

The 1-to-3 adjacent jumper for continuous commoning enables every other terminal block to be commoned. For example, positive and negative potentials can be accommodated alongside each other.

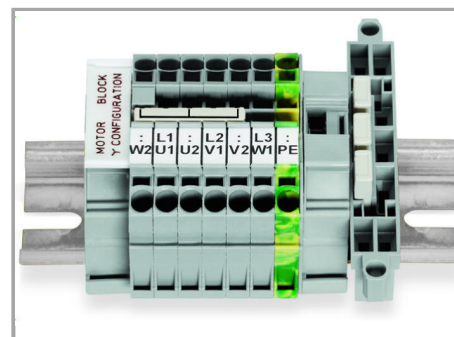

This star point jumper has been specially developed to create a "star point" and is used on motor terminal boards equipped with TOPJOB® S rail-mount terminal blocks.

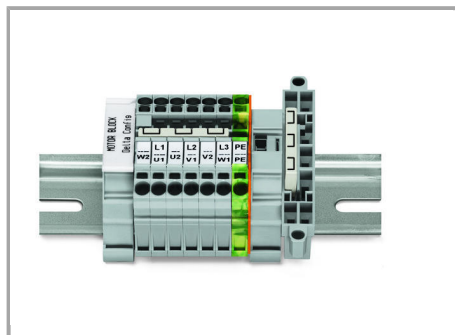

This delta jumper has been specially developed to create a delta configuration and is used on motor terminal boards equipped with TOPJOB® S rail-mount terminal blocks.

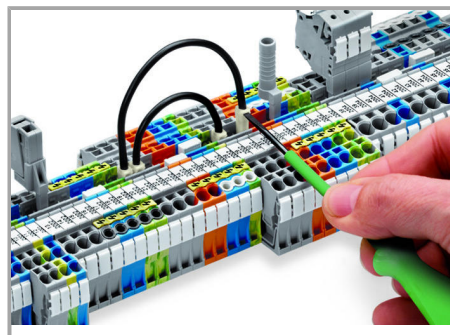

Push down the wire jumper until fully inserted. Lift the jumper with an operating tool for rewiring.

Jumpered

Zmiany zastrzeżone

WAGO ELWAG sp. z o. o.
 ul. Piękna 58 a
 50-506 Wrocław
 Tel.: +48 71 3602972 | Fax: +48 71 3602999
 Email: wago.elwag@wago.com

Masz pytania dotyczące naszych produktów?
 Jesteśmy do Twojej dyspozycji pod numerem telefonu +48 71 360 29 70.

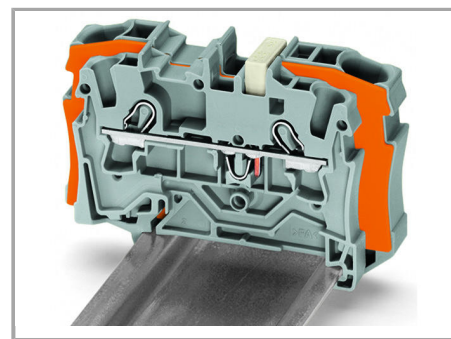
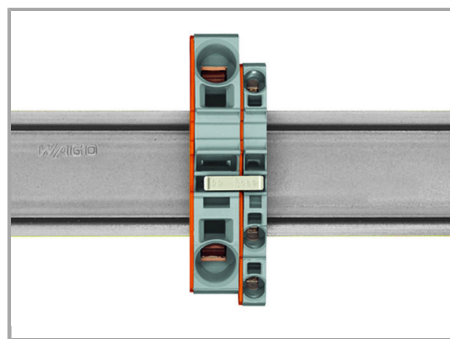
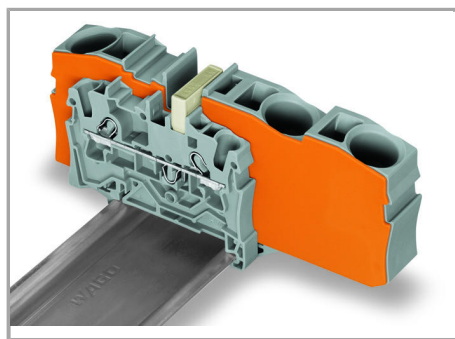

Step-down jumpers may common terminal blocks of different sizes, without losing a conductor clamping point. This can be beneficial on long conductor runs where voltage drops may be problematic. A large conductor can be easily connected to smaller conductors at the distribution point.

Using step-down jumpers, an end plate must be inserted between the terminal blocks to be commoned.

Step-down jumper (2006-499) commons 6 /4 mm² (10/12 AWG) terminal blocks (2006 /2004 Series) with 4/2.5/1.5 mm² (12/14/16 AWG) terminal blocks (2004/2002/2001 Series).

Commoning may be made in either direction using the special thin end plate to cover the open side. Additional through terminal blocks having a smaller cross-section may be commoned using push-in type jumper bars.

Zmiany zastrzeżone

WAGO ELWAG sp. z o. o.
ul. Piękna 58 a
50-506 Wrocław
Tel.: +48 71 3602972 | Fax: +48 71 3602999
Email: wago.elwag@wago.com

Masz pytania dotyczące naszych produktów?
Jesteśmy do Twojej dyspozycji pod numerem telefonu +48 71 360 29 70.

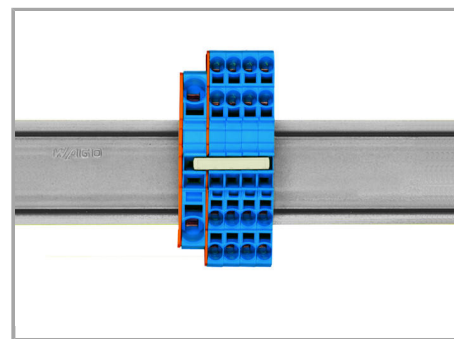
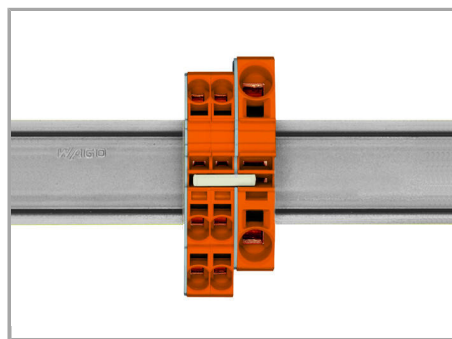
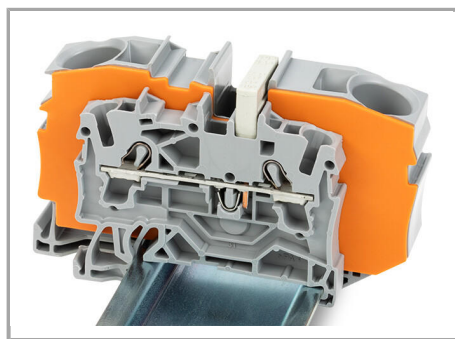

Step-down jumper (2016-499) commons 16 /10 mm² (16/8 AWG) terminal blocks (2016 /2010 Series) with 10/6/4/2.5 mm² (8/10/12 /14 AWG) terminal blocks (2010/2006/2004 /2002 Series).

Stepping down via push-in type jumper bar.

Commoning via open terminal side with end plate allows jumpering over two cross-section sizes for 16 mm² (6 AWG) and 10 mm² (8 AWG) and one cross-section size for 6/4/2.5 mm² (10/12/14 AWG). An example: from 16 mm² (6 AWG) to 6 mm² (10 AWG) (see illustration above) or from 10 mm² (8 AWG) to 4 mm² (12 AWG).

Stepping down via push-in type jumper bar.

Commoning via closed terminal side with end plate allows jumpering over two cross-section sizes, e.g., from 16 mm² (6 AWG) to 6 mm² (10 AWG) or from 6 mm² (10 AWG) to 2.5 mm² (14 AWG) (see illustration above).

Zmiany zastrzeżone

WAGO ELWAG sp. z o. o.
ul. Piękna 58 a
50-506 Wrocław
Tel.: +48 71 3602972 | Fax: +48 71 3602999
Email: wago.elwag@wago.com

Masz pytania dotyczące naszych produktów?
Jesteśmy do Twojej dyspozycji pod numerem telefonu +48 71 360 29 70.

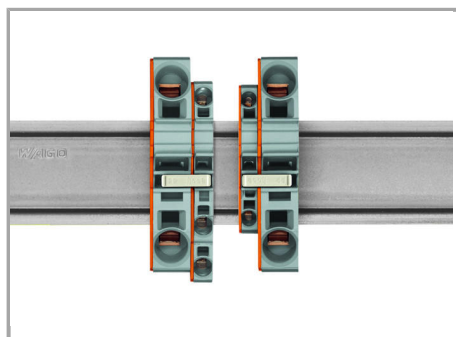

Note:

The total current of the outgoing circuits shall not exceed the nominal current of the step-down jumper/push-in type jumper bar.

Testing

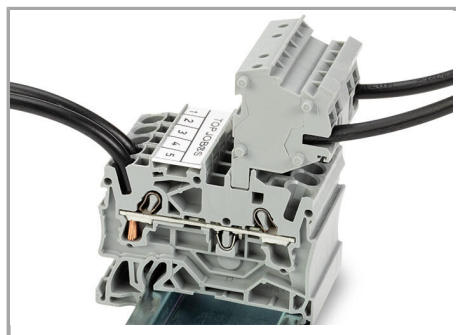

The modular TOPJOB® S connectors also connect conductors of the same size as the terminal blocks being used.

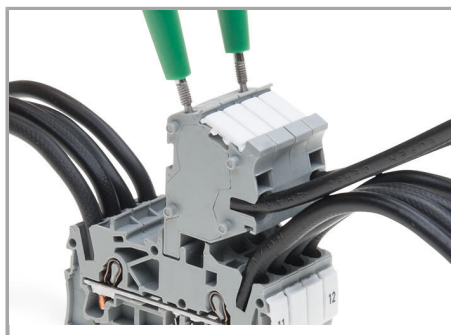

TOPJOB® S Connectors with a 2 mm Ø test socket for testing voltage via 2-pole voltage tester

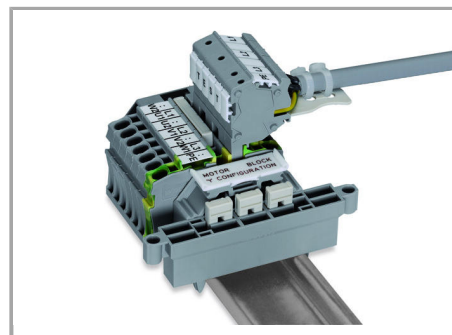

Rail-mount terminal block assembly for electric motor wiring

Zmiany zastrzeżone

WAGO ELWAG sp. z o. o.
ul. Piękna 58 a
50-506 Wrocław
Tel.: +48 71 3602972 | Fax: +48 71 3602999
Email: wago.elwag@wago.com

Masz pytania dotyczące naszych produktów?
Jesteśmy do Twojej dyspozycji pod numerem telefonu +48 71 360 29 70.

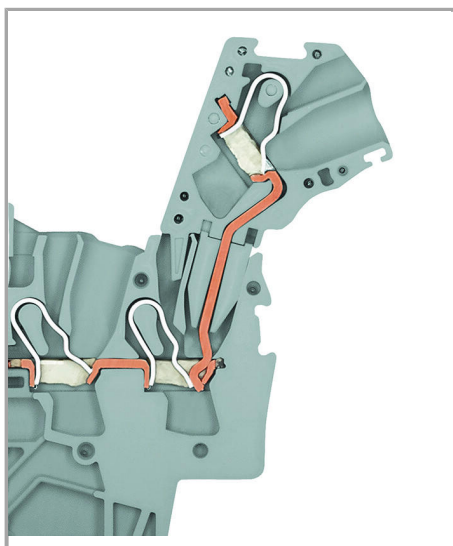

L-type test plug module – cross-sectional view of contacts

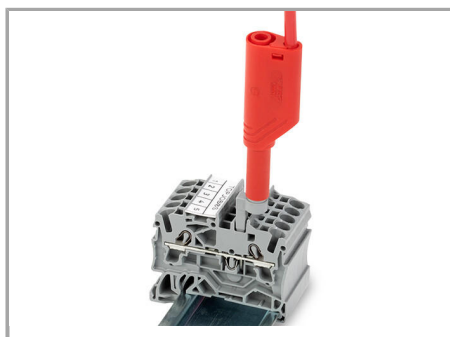

Test plug adapter (2009-174, CAT I) for 4 mm Ø plugs – compatible with 2000 to 2016 Series

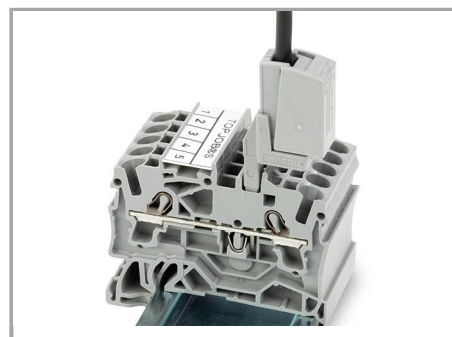

Testing tap (2009-182) for tool-free connection of test cables up to 2.5 mm² (12 AWG) – compatible with 2000 to 2016 Series

Marking

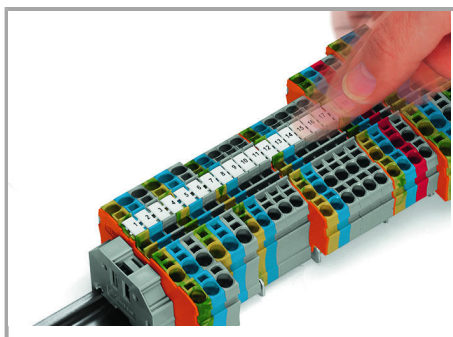

Snapping WMB Inline markers into marker slots.

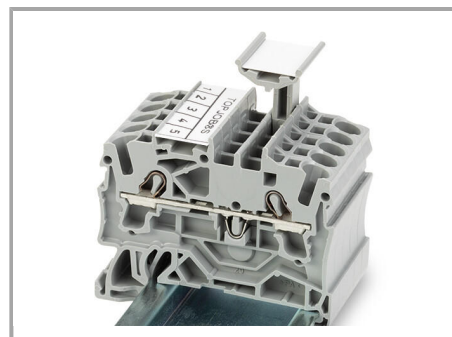
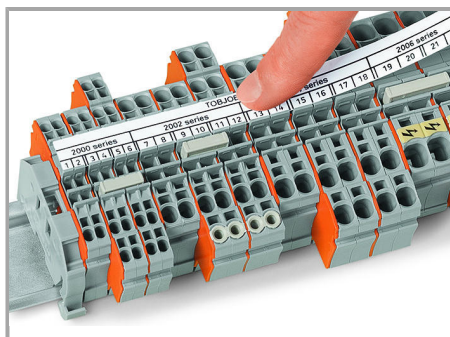

TOPJOB® S 2009-193 Group Marker Carrier (equipped with a marking strip) for all 2001 to 2016 Series TOPJOB® S Rail-Mount Terminal Blocks

Do not use on an end plate!

Zmiany zastrzeżone

WAGO ELWAG sp. z o. o.
ul. Piękna 58 a
50-506 Wrocław
Tel.: +48 71 3602972 | Fax: +48 71 3602999
Email: wago.elwag@wago.com

Masz pytania dotyczące naszych produktów?
Jesteśmy do Twojej dyspozycji pod numerem telefonu +48 71 360 29 70.

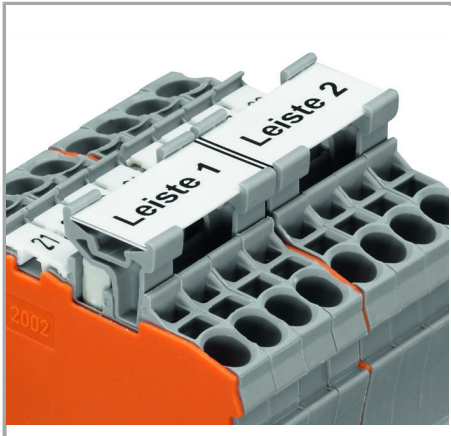

Using marker carriers for marking strips (2002-161) in jumper slots.

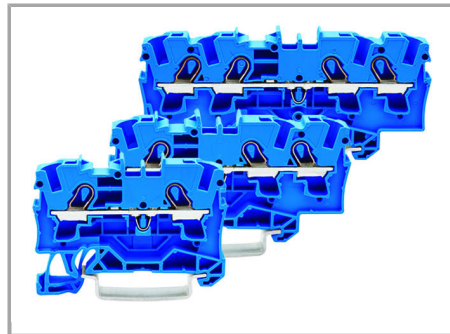
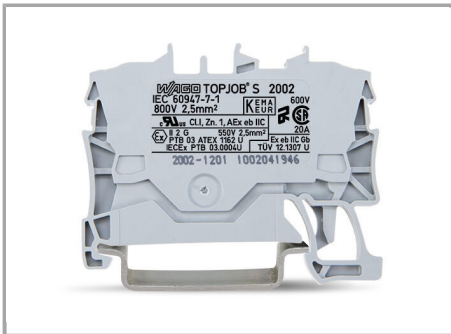

Through terminal blocks with a blue insulated housing are suitable for Ex i applications.



All through and ground conductor terminal blocks are suitable for Ex e II applications.

Zmiany zastrzeżone

WAGO ELWAG sp. z o. o.
ul. Piękna 58 a
50-506 Wrocław
Tel.: +48 71 3602972 | Fax: +48 71 3602999
Email: wago.elwag@wago.com

Masz pytania dotyczące naszych produktów?
Jesteśmy do Twojej dyspozycji pod numerem telefonu +48 71 360 29 70.

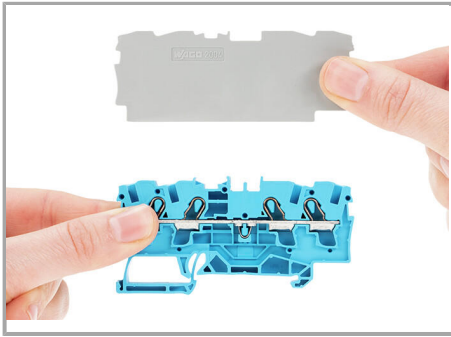

Separator for Ex e/Ex applications

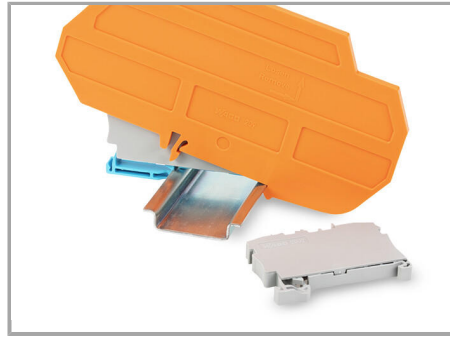

Ex e II/Ex i terminal strip

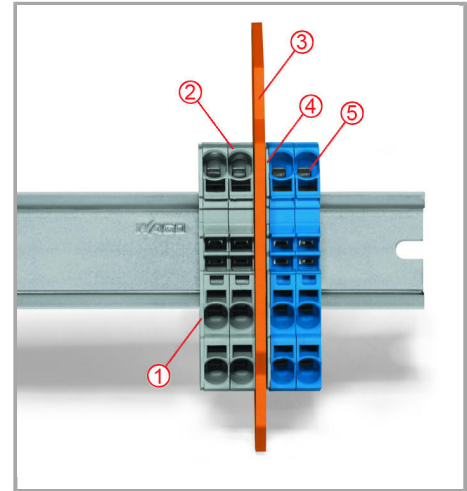

Separator located between Ex e II and Ex i terminal strip

An end plate must be applied to the terminal block located directly behind an Ex e/Ex i separator plate.

Notice:

The movable feet of terminal blocks and separator plates must face the same direction.

End plate

Ex e II terminal blocks

Separator for Ex e/Ex i applications

End plate

Ex i terminal blocks

According to EN 50020, a minimum distance of 50 mm must be kept between live parts of Ex e and Ex i circuits. The use of Ex e/Ex i separators is a space-saving solution when Ex e and Ex i terminal blocks are mounted on a common carrier rail.

Zmiany zastrzeżone

WAGO ELWAG sp. z o. o.
ul. Piękna 58 a
50-506 Wrocław
Tel.: +48 71 3602972 | Fax: +48 71 3602999
Email: wago.elwag@wago.com

Masz pytania dotyczące naszych produktów?
Jesteśmy do Twojej dyspozycji pod numerem telefonu +48 71 360 29 70.