



Low Voltage Products and Systems

We ensure safety and comfort for everyday life by bringing electric power to domestic appliances, lighting and heating.

Through our comprehensive range of enclosures, line protection equipment, wiring accessories and various other components to complete any electrical

installation we cover the full spectrum of equipment required for control and protection of all domestic and residential installations.

With this EIB system all electrical functions in a home can now be programmed and remotely controlled.

Domestic and residential buildings



Commercial and industrial buildings



All over the world office buildings, hospitals, hotels, public buildings, shopping centers, sport complexes and city lighting projects are equipped with ABB Low Voltage Products and Systems.

From switchboard to light switch we cover the complete range of equipment required for control and protection of electrical installations.

Architects, consultants, builders and contractors appreciate the performance/cost ratio provided by our products.

They have made ABB a well known reference for high quality and extremely reliable electrical equipment.



Installation contactors Type ESB..

Contents

Installation contactors

Ordering details	4
Technical data	5
Switching lamp loads	7
Ordering details for accessories Location of the connection terminals	8
Approvals and certificates	8



Application

Automation processes in building wiring and installation can be implemented with installation contactors. They are used chiefly for switching and controlling lighting systems, heating systems, ventilation systems, pumps, heating pumps and other building automation actuators. Geräte für Schalttafeleinbau auf Tragschienen (35 mm) nach DIN EN 50 022

Installation depth: System 68 mm
Installation width: 1, 2 and 3 modules (1 module = 17.5 ... 18 mm)
Colour: grey, RAL 7035

suitable for the STOTZ system proM

Advantages

- hum-free solenoid drive
- low-noise switching
- switching position indicator
- integrated coil protective circuit
- attachable auxiliary switch
- overvoltage protection for the solenoid coil up to 5 kV
- high making/breaking capacity and long service life
- quick fastening with latching slide
- large connections with open box terminals
- shock-hazard protection to VDE 0106, Part 100

Construction

Type ESB 20 operates with an AC solenoid system. Types ESB 24, 40 and 63 feature a DC solenoid actuator and are thus hum-free. The noise during switching on is hardly audible compared with an AC solenoid. An integrated diode jumper allows connection to AC voltage. The incorporated varistor protects the coil against remote lightning strikes and overvoltages of up to 5 kV. In addition, it limits the interference voltage peaks of the solenoid system. The contactors can therefore be combined with programmable logic controllers. There is no need for a coil protective circuit. The solenoid system is provided with radio interference suppression.

Overvoltage peaks may cause a current of max. 200 A resp. an energy of max. 4 J or $10^6 \times$ a current of 5 A resp. an energy of max. 0.05 J with normal wave (8/20 μ s).

All switching elements of the contactors can be used as main contact elements or as auxiliary contact elements (see also technical data). The contacts are not positively driven, and NO and NC contacts can therefore overlap.

On Types ESB 24, 40 and 63, a two-pole auxiliary switch, Type EH 04 (1/2 module width) can be attached. This auxiliary switch must be used for switching control signals.

Contactors ESB 20, 24 and 40 are also available as "EN" devices with integrated manual switch, e.g. for "day/night" application. Data sheet on request.

Installation contactors ESB..

Ordering details

Accessories

IEC 947-4-1
EN 60 947-4-1
IEC 1095
EN 61 095

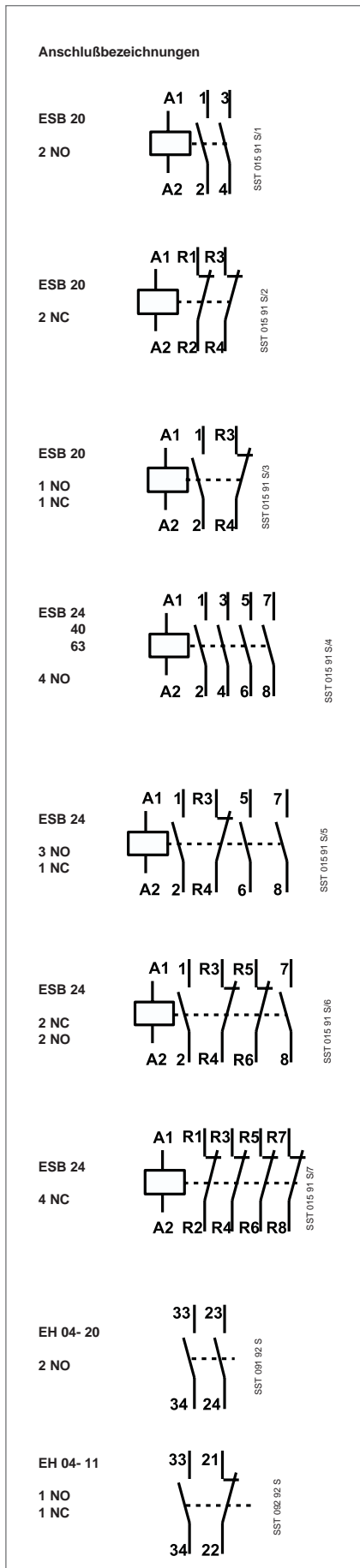

Contactor type Contact complement ②	Rated operating voltage ①		Order code Product No.	bbn 40 13614 EAN	Price 1 St. DM	Weight 1 piece kg	Pack. unit piece						
	50 Hz	60 Hz											
ESB 20-20 2 NO	12 V	14 V	GH E321 1102 R 1004	08427 0 08420 1 08421 8 08422 5 08423 2 08425 6 08424 9 08426 3		0.2	10						
	24 V	27 ... 28 V	GH E321 1102 R 0001										
	42 V	48 V	GH E321 1102 R 0002										
	48 V	55 V	GH E321 1102 R 0003										
	110 V	125 ... 127 V	GH E321 1102 R 0004										
	230 V	255 V	GH E321 1102 R 0006										
	231... 244 V	268 ... 283 V	GH E321 1102 R 0005										
	400 V	–	GH E321 1102 R 0007										
	ESB 20-02 2 NC	12 V	14 V					GH E321 1202 R 1004	08517 8 08430 0 08431 7 08518 5 08432 4 08433 1 08519 2 08520 8		0.2	10	
		24 V	27 ... 28 V					GH E321 1202 R 0001					
42 V		48 V	GH E321 1202 R 0002										
48 V		55 V	GH E321 1202 R 0003										
110 V		125 ... 127 V	GH E321 1202 R 0004										
230 V		255 V	GH E321 1202 R 0006										
231... 244 V		268 ... 283 V	GH E321 1202 R0005										
400 V		–	GH E321 1202 R0007										
ESB 20-11 1 NO 1 NC		12 V	14 V	GH E321 1302 R 1004	08515 4 08435 5 08436 2 08514 7 08437 9 08439 3 08438 6 08516 1		0.2	10					
		24 V	27 ... 28 V	GH E321 1302 R 0001									
	42 V	48 V	GH E321 1302 R 0002										
	48 V	55 V	GH E321 1302 R 0003										
	110 V	125 ... 127 V	GH E321 1302 R 0004										
	230 V	255 V	GH E321 1302 R 0006										
	231... 244 V	268 ... 283 V	GH E321 1302 R 0005										
	400 V	–	GH E321 1302 R 0007										
	ESB 24-40 4 NO	12 V	AC 40 ... 450 Hz or DC	GH E329 1102 R 1004					08447 8 08441 6 08442 3 08546 8 08443 0 GH E329 1102 R 0006 08445 4 08446 1		0.28	5	
		24 V		GH E329 1102 R 0001									
42 V		GH E329 1102 R 0002											
48 V		GH E329 1102 R 0003											
110 ... 120 V		GH E329 1102 R 0004											
230 ... 240 V		GH E329 1102 R 0006											
400 ... 415 V		GH E329 1102 R 0007											
ESB 24-04 4 NC		12 V		AC 40 ... 450 Hz or DC	GH E329 1202 R 1004	08456 0 08451 5 08452 2 08548 2 08453 9 GH E329 1202 R 0006 08454 6 08455 3		0.28					5
		24 V			GH E329 1202 R 0001								
		42 V			GH E329 1202 R 0002								
	48 V	GH E329 1202 R 0003											
	110 ... 120 V	GH E329 1202 R 0004											
	230 ... 240 V	GH E329 1202 R 0006											
	400 ... 415 V	GH E329 1202 R0007											
	ESB 24-22 2 NO 2 NC	12 V	AC 40 ... 450 Hz or DC		GH E329 1302 R 1004				08463 8 08458 4 08459 1 08552 9 08460 7 GH E329 1302 R 0006 08461 4 08525 3		0.28	5	
		24 V			GH E329 1302 R 0001								
		42 V			GH E329 1302 R 0002								
48 V		GH E329 1302 R 0003											
110 ... 120 V		GH E329 1302 R 0004											
230 ... 240 V		GH E329 1302 R 0006											
400 ... 415 V		GH E329 1302 R0007											
ESB 24-31 3 NO 1 NC		12 V		AC 40 ... 450 Hz or DC	GH E329 1602 R 1004	08472 0 08467 6 08468 3 08555 0 08469 0 08470 6 08471 3		0.28					5
		24 V			GH E329 1602 R 0001								
		42 V			GH E329 1602 R 0002								
	48 V	GH E329 1602 R 0003											
	110 ... 120 V	GH E329 1602 R 0004											
	230 ... 240 V	GH E329 1602 R 0006											
	400 ... 415 V	GH E329 1602 R 0007											
	ESB 24-13 1 NO 3 NC	12 V	AC 40 ... 450 Hz or DC		GH E329 1702 R 1004				21825 5 21478 3 21820 0 21821 7 21822 4 GH E329 1702 R 0006 21823 1 21824 8		0.28	5	
		24 V			GH E329 1702 R 0001								
		42 V			GH E329 1702 R 0002								
48 V		GH E329 1702 R 0003											
110 ... 120 V		GH E329 1702 R 0004											
230 ... 240 V		GH E329 1702 R 0006											
400 ... 415 V		GH E329 1702 R0007											
ESB 40-40 4 NO ③		24 V		AC 40 ... 450 Hz. or DC	GH E349 1102 R 0001	08482 9 08483 0 08559 8 08484 3 08486 7 08529 1 08530 7 08560 4		0.45					3
		42 V			GH E349 1102 R 0002								
		48 V			GH E349 1102 R 0003								
	110 V	GH E349 1102 R 0004											
	230 V	GH E349 1102 R 0006											
	240 V	GH E349 1102 R 0005											
	400 V	GH E349 1102 R 0007											
	415 V	GH E349 1102 R 0008											
	ESB 63-40 4 NO ③	24 V	AC 40 ... 450 Hz or DC		GH E369 1102 R 0001				08493 5 08494 2 12725 0 08495 9 08497 3 08535 2 08498 0 12726 7		0.45	3	
		42 V			GH E369 1102 R 0002								
48 V		GH E369 1102 R 0003											
110 V		GH E369 1102 R 0004											
230 V		GH E369 1102 R 0006											
240 V		GH E369 1102 R 0005											
400 V		GH E369 1102 R 0007											
415 V		GH E369 1102 R 0008											

① Other voltages on request.

② "Day/night" installation contactors, Type EN 20, EN24, EN 40 on request.

③ Only delivery from ABB-Control France. 1 or 2 NC up to max. 30 A (AC-1) possible.

Installation contactors ESB..

Technical data

IEC 947-4-1
EN 60 947-4-1
IEC 1095
EN 61 095



ESB 20

SST 040 94 R



ESB 24

SST 041 94 R



ESB 40/ESB 63

SST 035 94 R



ESB 24 + EH 04

SST 038 94 R



EN 24

SST 038 95

Rated operating currents and power ratings

AC-1 / AC-7a	ESB 20	ESB 24	ESB 40	ESB 63
Rated operating current I _e (NO)	20 A	24 A	40 A	63 A
Rated operating current I _e (NC)	20 A	24 A	30 A	30 A
2 current paths connected in parallel permit a 1.6-fold increase in rated operating current I _e .				
Rated operating power (NO)				
230 V single-phase	4.0 kW	5.3 kW	8.8 kW	13.8 kW
230 V 3-phase	–	9.0 kW	15.2 kW	24.0 kW
400 V 3-phase	–	16.0 kW	26.0 kW	41.0 kW
AC-3/AC-7b Switching motors				
Rated operating current I _e (NO)	9 A	9 A	22 A	30 A
Rated operating current I _e (NC)	9 A	6 A		
Rated operating power (NO)				
230 V single-phase	1.3 kW	1.3 kW	3.7 kW	5.0 kW
230 V 3-phase	–	2.2 kW	5.5 kW	8.0 kW
400 V 3-phase	–	4.0 kW	11.0 kW	15.0 kW

DC-1/DC-3 Switching DC with NO contacts (NO)

Type	Rated operating voltage U _e	DC-1 (L/R ≤ 1 ms)			DC-3 (L/R ≤ 2 ms)		
		1 current path	2 current paths in series	3 current paths in series	1 current path	2 current paths in series	3 current paths in series
ESB 24	24 V DC	24.0 A	24.0 A	24.0 A	16.0 A	24.0 A	24.0 A
	48 V DC	21.0 A	24.0 A	24.0 A	8.0 A	18.0 A	24.0 A
	60 V DC	17.0 A	24.0 A	24.0 A	4.0 A	14.0 A	24.0 A
	110 V DC	7.0 A	16.0 A	24.0 A	1.6 A	6.5 A	16.0 A
	220 V DC	0.9 A	4.5 A	13.0 A	0.2 A	1.0 A	4.0 A
ESB 40	24 V DC	40.0 A	40.0 A	40.0 A	19.0 A	40.0 A	40.0 A
	48 V DC	23.0 A	40.0 A	40.0 A	10.0 A	20.0 A	40.0 A
	60 V DC	18.0 A	32.0 A	40.0 A	5.0 A	16.0 A	34.0 A
	110 V DC	8.0 A	17.0 A	30.0 A	1.8 A	7.0 A	18.0 A
	220 V DC	1.0 A	5.0 A	15.0 A	0.3 A	1.1 A	4.5 A
ESB 63	24 V DC	50.0 A	63.0 A	63.0 A	21.0 A	44.0 A	63.0 A
	48 V DC	25.0 A	43.0 A	63.0 A	11.0 A	22.0 A	47.0 A
	60 V DC	20.0 A	35.0 A	60.0 A	5.5 A	18.0 A	38.0 A
	110 V DC	9.0 A	19.0 A	33.0 A	2.0 A	8.0 A	21.0 A
	220 V DC	1.1 A	5.5 A	17.0 A	0.3 A	1.2 A	5.0 A

DC-1/DC-3 Switching DC with NC contacts (NC)

Type	Rated operating voltage U _e	DC-1 (L/R ≤ 1 ms)			DC-3 (L/R ≤ 2 ms)		
		1 current path	2 current paths in series	3 current paths in series	1 current path	2 current paths in series	3 current paths in series
ESB 24	24 V DC	14.5 A	24.0 A	24.0 A	6.3 A	11.0 A	19.0 A
	48 V DC	7.5 A	12.5 A	22.0 A	3.1 A	5.4 A	9.4 A
	60 V DC	4.5 A	10.0 A	17.5 A	2.0 A	4.3 A	7.5 A
	110 V DC	1.6 A	4.4 A	9.5 A	0.7 A	1.9 A	4.1 A
	220 V DC	0.2 A	1.4 A	3.8 A	0.1 A	0.6 A	1.6 A

Contactors type	Order code	Rated operating current	Rated operating current
EN 24-40 24 V	GHE 3261 101 R0001	24 A	24 V
EN 24-40 230-240 V	GHE 3261 101 R0006	24 A	230-240 V
EN 24-30 230-240 V	GHE 3261 501 R0006	24 A	230-240 V
EN 24-31 24 V	GHE 3261 601 R0001	24 A	24 V
EN 24-31 230-240 V	GHE 3261 601 R0006	24 A	230-240 V
EN 40-40 230 V	GHE 3421 101 R0006	24 A	230 V

Switching lamp loads, see Page 7.

Installation contactors ESB..

Technical data

of ESB.. and auxiliary switches

IEC 947-4-1
EN 60 947-4-1
IEC 1095
EN 61 095

Contact member service life

AC-1/400 V/3-phase for ESB 24, 40, 63
AC-1/230 V/single-phase for ESB 20

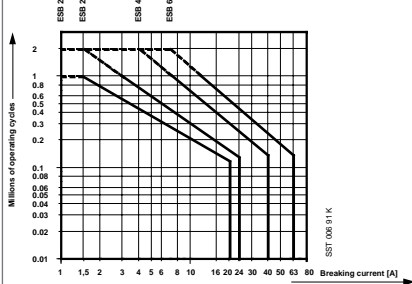

AC-3/400 V/3-phase for ESB 24, 40, 63

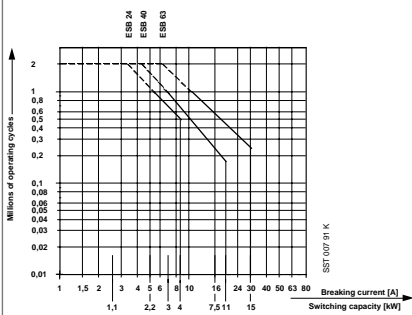

Dimensions in mm

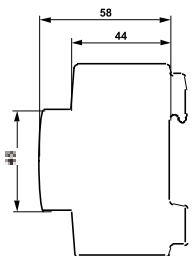

Type	Overall width A
ESB 20	1 module (18.0 mm)
ESB 24	2 modules (36.0 mm)
ESB 40	3 modules (54.0 mm)
ESB 63	3 modules (54.0 mm)
EH 04	0.5 module (9.0 mm)

	ESB 20	ESB 24	ESB 40	ESB 63
Rated insulation voltage U_i	400 V	500 V	500 V	500 V
Rated operation voltage U_e	250 V	440 V	440 V	440 V
Short-circuit protection				
Back-up fuse, Type "gL/gG"	20 A	35 A	63 A	80 A
Limiting short-time current 10 s at ambient temperature $\leq 40^\circ\text{C}$, in free air, from cold state	72 A	72 A	176 A	240 A
Ohmic loss per current path at I_e (AC-1, AC-7a)	1.0 W	1.5 W	3.0 W	6.0 W

Contact member service life and max. switching frequency

Service life	mechanical	1 million	1 million	1 million	1 million
	electrical at AC-1 / AC-7a	150 000	150 000	150 000	150 000
	at AC-3 / AC-7b	150 000	500 000	170 000	240 000
Max. switching frequency					
	AC-1 / AC-7a	300 operations/hour			
	AC-3 / AC-7b	600 operations/hour			
Permissible mains frequency		50 ... 60 Hz			
Min. making/breaking capacity		17 V / 200 mA			

Characteristics of the solenoid system

Operating range of solenoid coil	85 ... 110 % der Bemessungsbetätigungsspannung U_c			
Reliable switch-off between	20 ... 75% U_c	10 ... 75% U_c		
Frequency range	50/60 Hz	40 ... 450 Hz AC or DC		
Relative duty ED	100%			

Power consumption of the solenoid coil

pick-up	-	8.0VA, 5.0W	4.0VA, 4.0W	5.0VA, 5.0W	65 VA, 65 W
holding	-	3.2VA, 1.2W	4.0VA, 4.0W	5.0VA, 5.0W	4.2 VA, 4.2 W
On delay		≤ 12 ms	≤ 40 ms		
Off delay		≤ 12 ms	≤ 40 ms		

Permissible Ambient temperature

- 25 °C to + 55 °C

If several contactors are mounted adjacently and the On time is longer than one hour, every second contactor needs a distance piece, Type ESB-DIS (1/2 module). This is not necessary at an ambient temperature $\leq 40^\circ\text{C}$ or on Type ESB 20.

Connection cross-sections

Main conductor	max. mm ²	1 x 10 or 2 x 4	1 x 25 or 2 x 10
	min. mm ²	1 x 0.5	1 x 1.5
Coil mm²		1 x 4 or 2 x 2.5	

Auxiliary switch EH 04

Thermal continuous current $I_n = 6$ A

Rated operating current I_e at AC-15 for $U_e \leq 240$ V AC 4 A
 ≤ 415 V AC 3 A
 ≤ 500 V AC 2 A

Minimum making/breaking capacity ≥ 17 V / ≥ 5 mA

Installation contactors ESB..

Technical data

Switching lamp loads

IEC 947-4-1
EN 60 947-4-1
IEC 1095
EN 61 095

Switching lamp loads

Please note the following:

The following table shows the number of lamps which can be connected per circuit at 230 V/50 Hz.

If the specified capacitor load is exceeded, this may result in admissibly high peak inrush currents. Other factors which influence the magnitude of peak inrush currents are as follows:

- Length and cross-section of installed supply cables
- Type of electronic ballast units
- Lamp make

The following lamp load table thus contains non-binding guideline values.

Lamp type	Lamp data		Permissible number of lamps per circuit (230 V, 50 Hz) in the case of contactor type				Capacitor load in μF	
	Watt	I_n A	ESB	ESB	ESB	ESB		
			20	24	40	63		
Incandescent lamps	60	0.26	21	25	54	83		
	100	0.43	13	15	32	50		
	200	0.87	7	7	16	25		
	300	1.30	4	5	11	16		
	500	2.17	3	3	6	10		
	1000	4.35	1	1	3	5		
	Fluorescent lamps, p.f. uncorrected and series p.f. correction	15	0.33	25	30	100	155	
20		0.37	22	26	85	135		
40		0.43	17	20	65	105		
58		0.67	10	12	40	65		
65		0.67	10	12	40	65		
115		1.5	4	5	18	28		
140		1.5	4	5	18	28		
Lead-lag circuit	2 x 20	2 x 0.13	2 x 22	2 x 26	2 x 85	2 x 140		
	2 x 40	2 x 0.22	2 x 17	2 x 20	2 x 65	2 x 105		
	2 x 58	2 x 0.32	2 x 10	2 x 12	2 x 40	2 x 65		
	2 x 65	2 x 0.34	2 x 10	2 x 12	2 x 40	2 x 65		
	2 x 115	2 x 0.65	2 x 4	2 x 5	2 x 18	2 x 28		
	2 x 140	2 x 0.75	2 x 4	2 x 5	2 x 18	2 x 28		
	Parallel p.f. correction	15	0.11	6	8	16	67	4.5
20		0.13	6	8	16	67	4.5	
40		0.22	6	8	16	67	4.5	
58		0.32	4	5	10	43	7	
65		0.34	4	5	10	43	7	
115		0.65	1	2	4	17	18	
140		0.75	1	2	4	17	18	
High-pressure mercury-vapour lamps	50	0.61	12	14	36	50		
	80	0.8	7	10	27	38		
	125	1.15	5	7	19	26		
	250	2.15	3	4	10	14		
	400	3.25	1	2	7	10		
	700	5.40	-	1	4	6		
	1000	7.5	-	1	3	4		
Parallel p.f. correction	50	0.28	4	5	10	43	7	
	80	0.41	3	4	8	37	8	
	125	0.65	2	3	6	26	10	
	250	1.22	1	2	3	15	18	
	400	1.95	-	1	3	10	25	
	700	3.45	-	-	1	5	45	
	1000	4.8	-	-	1	4	60	
Lamps with electronic ballast units (EVG)	2000/400 V	5.45	-	1	2	3	35	
	EVG für Watt	Permissible number of electronic ballast units per circuit (230 V, 50 Hz)						
		1 x 18	-	15	24	55	76	
		2 x 18	-	8	18	34	48	
		1 x 36	-	12	16	34	47	
		2 x 36	-	7	11	20	29	
		1 x 58	-	11	14	32	46	
2 x 58	-	6	8	17	24			
Halogen metal-vapour lamps, p.f. uncorrected	35	0.53	-	10	28	38		
	70	1	-	5	14	20		
	150	1.8	-	3	8	11		
	250	3	-	2	5	7		
	400	3.5	-	1	4	6		
	1000	9.5	-	-	1	2		
	2000	16.5	-	-	1	1		
Parallel p.f. correction	2000/3500/400 V	10.5	-	-	2	2		
		18	-	-	1	1		
		-	-	-	-	-		
	35	0.25	-	5	11	30	6	
	70	0.45	-	3	5	18	12	
	150	0.75	-	1	3	9	20	
	250	1.5	-	1	2	7	33	
400	2.5	-	1	2	6	35		
1000	5.8	-	-	-	2	95		
2000	11.5	-	-	-	1	148		
Low-pressure mercury-vapour lamps p.f. uncorrected	2000/3500/400 V	6.6	-	-	1	2	58	
		11.6	-	-	-	1	100	
		-	-	-	-	-		
	35	1.5	5	8	22	30		
	55	1.5	5	8	22	30		
	90	2.4	3	5	13	19		
	135	3.5	2	3	10	13		
150	3.3	2	3	10	14			
180	3.3	2	3	10	14			
200	2.3	3	5	14	20			
Parallel p.f. correction	35	0.31	-	1	4	15	20	
	55	0.42	-	1	4	15	20	
	90	0.63	-	1	3	10	30	
	135	0.94	-	-	2	7	45	
	150	1.0	-	-	2	8	40	
	180	1.16	-	-	2	8	40	
	200	1.32	-	1	3	12	25	
High-pressure sodium-vapour lamps	150	1.8	-	4	15	20		
	250	3.0	-	3	9	15		
	330	3.7	-	2	8	10		
	400	4.7	-	1	6	8		
	1000	10.3	-	-	3	4		
	Parallel p.f. correction	150	0.83	-	1	3	15	20
		250	1.5	-	1	2	9	33
330		2.0	-	-	2	7	40	
400		2.4	-	-	1	6	48	
1000		6.3	-	-	-	2	106	
Transformers for halogen low-volt lamps		Transformers for		Permissible number of transformers per circuit (230 V, 50 Hz)				
		Watt						
	20		40	52	110	174		
	50		20	24	50	80		
	75		13	16	35	54		
	100		10	12	27	43		
	150		7	9	19	29		
200		5	6	14	23			
300		3	4	9	14			

Installation contactors ESB..

Accessories, location of the connection terminals Approvals and certificates

IEC 947-4-1
EN 60 947-4-1
IEC 1095
EN 61 095

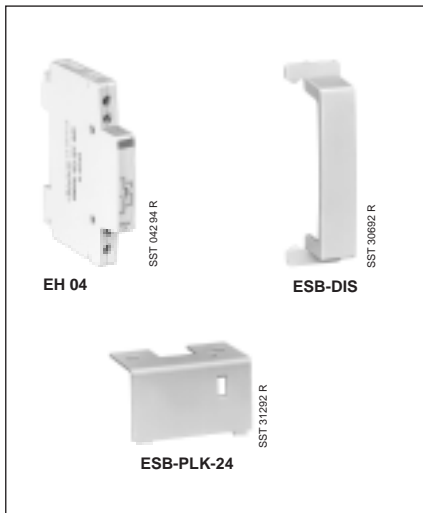

Accessories ①

Designation	Type Abbreviation	Order code	bbn 4012233 EAN	Price per piece DM	Weight per piece kg	Pack. unit piece
Aux. switches						
2 NO	EH 04-20	GH E340 1321 R 0001	08476 8		0.023	10
1 NO + 1 NC	EH 04-11	GH E340 1321 R 0002	08477 5		0.023	10
Distance piece ②	ESB-DIS	GH E320 1902 R 0001	08521 5		0.002	10
Sealing covers	ESB-PLK 24 ESB-PLK 40/63	GH E320 1903 R 0001 GH E340 1903 R 0001	08417 1 08527 7		0.002 0.003	10 10
Time relays	ETD24	On request				
On-delayed						

- ① Mounting onto ESB 20 not possible
② For usage, see Page 1/120 "Permissible ambient temperature"

Location of the connection terminals

Dimensions in mm

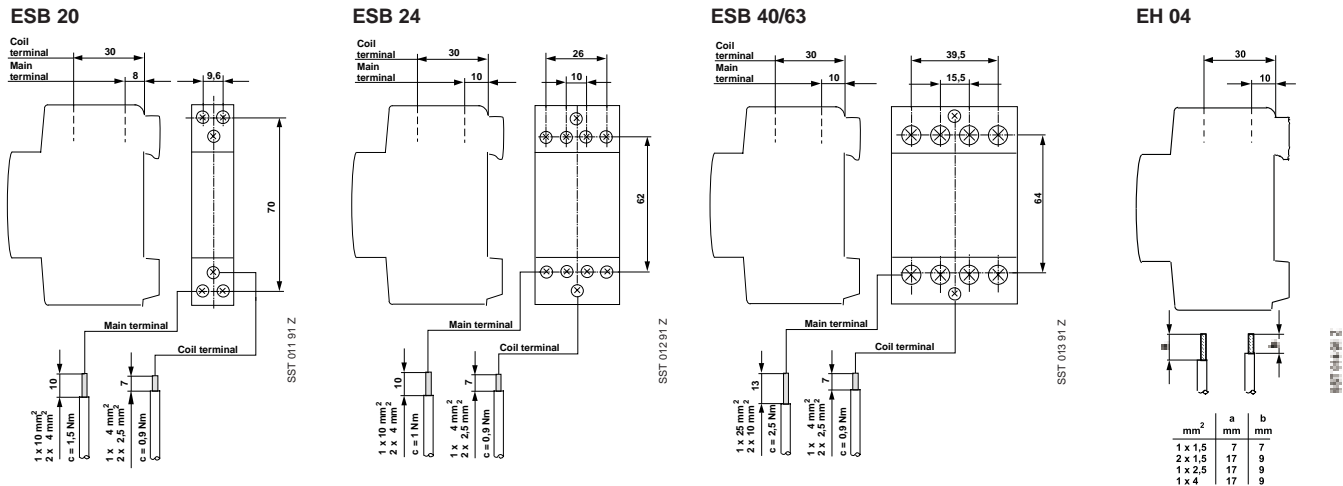

Connection screws

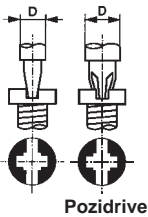

	ESB 20		ESB 24		ESB 40 / 63		EH 04	
	D _{max.}	Pozidrive Size	D _{max.}	Pozidrive Size	D _{max.}	Pozidrive Size	D _{max.}	Pozidrive Size
Main connection	5	1			7.5	2	5	1
Coil	5	1	1	1	5	1		

Approvals and certificates

Device type	Zulassungen										Ships' classification societies			
Test mark	SEV	DEMKO	NEMKO	SEMKO	EL.Inspect.	CEBEC	CSA	UL	EGC	NFUS	BV	GL	LRS	DNV
Abbreviation Validity	Switzerland	Denmark	Norway	Sweden	Finland	Belgium	Canada	USA	Czech. Rep.	France	France	Germany	Great Britain	Norway
ESB 20	■			■		■			■	●				
ESB 24		■	■	■	■	■		■	■	●	■	■	□	■
ESB 40			■			■		■	■	●	■	■	□	■
ESB 63			■			■		■	■	●	■	■	□	■

- Devices are approved. ● For NO contacts and control voltages 24 V and 230 V.
□ Devices have been submitted for approval or it is planned to submit them for approval.

Notes

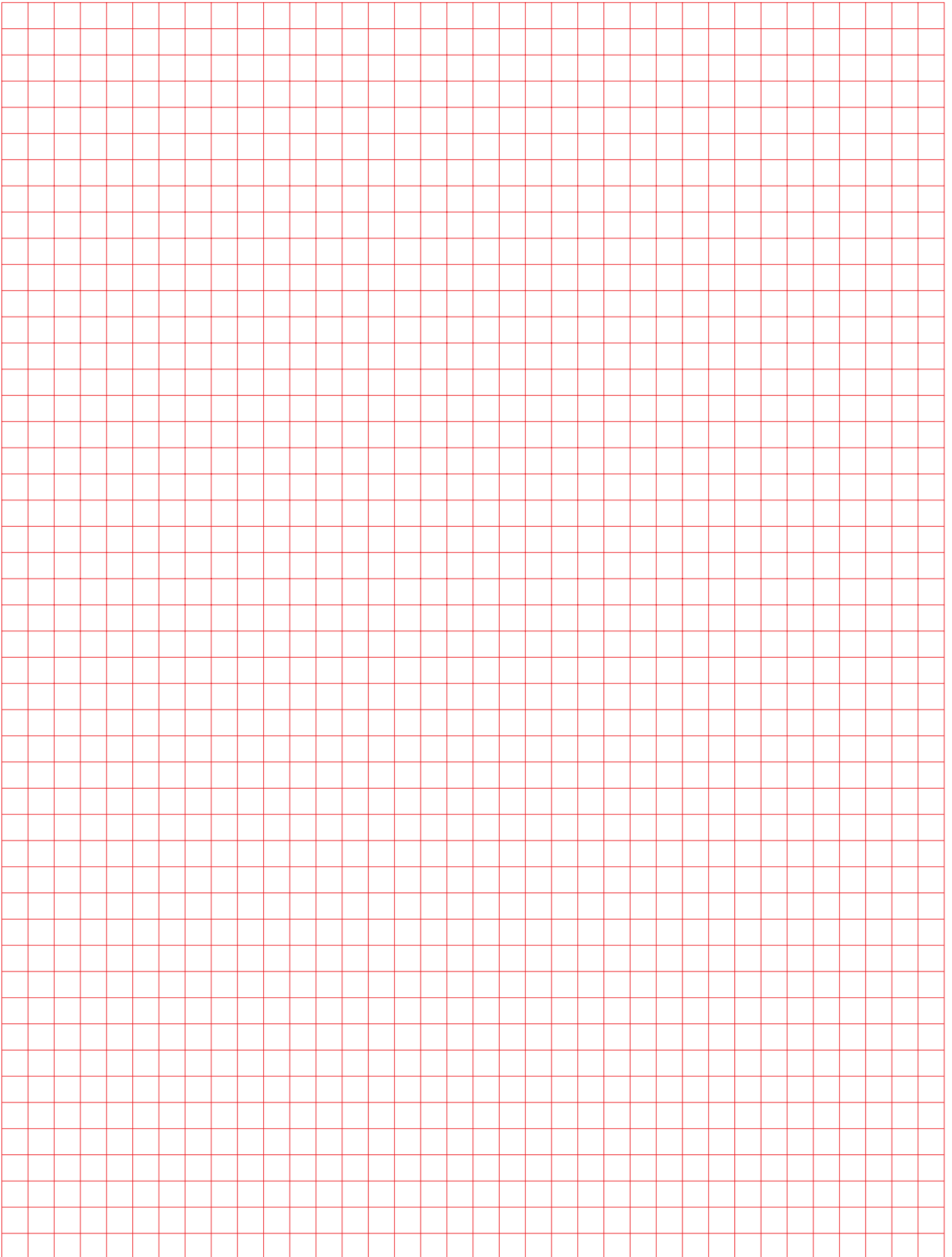



ABB STOTZ-KONTAKT GmbH
P.O.BOX 101680
D-69006 Heidelberg
Telephone ++49 62 21 / 701-00
Telefax ++49 62 21 / 701-1115
Internet <http://www.abb.de/sst>

Publication
no: 1SAC 1011 01 D0201
Printed in Germany (02/01)